

INSTALLATION and OWNER'S MANUAL FOR HIGH EFFICIENCY AIR-HANDLER

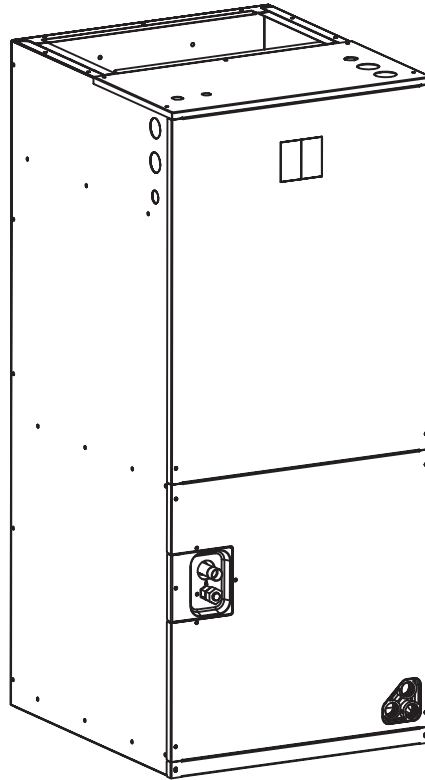

RECOGNIZE THIS SYMBOL AS AN INDICATION OF IMPORTANT SAFETY INFORMATION

WARNING

These instructions are intended as an aid to qualified licensed service personnel for proper installation, adjustment and operation of this unit. Read these instructions thoroughly before attempting installation or operation. Failure to follow these instruction may result in improper installation, adjustment, service or maintenance possibly resulting in fire, electrical shock, property damage, personal injury or death.

AHRI CERTIFIED[®]
www.ahridirectory.org

Unitary Small AC
AHRI Standard 210/240
Certification applies only When the complete system
is listed with AHRI.

AHRI CERTIFIED[®]
www.ahridirectory.org

Unitary Small HP
AHRI Standard 210/240
Certification applies only When the complete system
is listed with AHRI.



DO NOT DESTROY THIS MANUAL

Please read carefully and keep in a safe place for future reference by a serviceman.



INSTALLATION and OWNER'S MANUAL

**INDOOR SPLIT-SYSTEM UNIT
MODELS:UP TO 15 SEER
1.5 TO 5 TONS**

CONTENTS

1.0 KEY TO SYMBOLS AND SAFETY INSTRUCTIONS	2
1.1 KEY TO SYMBOLS	2
1.2 EXPLANATION OF SYMBOLS DISPLAYED ON THE UNIT	2
1.3 SAFETY	3
2.0 GENERAL	8
2.1 REFRIGERANT SENSOR	8
2.2 UNIT DIMENSIONS	10
2.3 PARTS INTRODUCTION	11
3.0 APPLICATIONS	12
3.1 VERTICAL UPFLOW	12
3.2 VERTICAL DOWNFLOW	12
3.3 HORIZONTAL	12
3.4 COIL PISTON REPLACE AND INSTALLATION	14
3.5 REFRIGERANT CHARGE AND ROOM AREA LIMITATIONS	15
3.6 THE ROOM AREA CALCULATION REQUIREMENTS	15
3.7 THE ALLOWED MAXIMUM REFRIGERANT CHARGE AND REQUIRED MINIMUM ROOM AREA	16
4.0 ELECTRICAL WIRING	18
4.1 POWER WIRING	18
4.2 CONTROL WIRING	18
4.3 GROUNDING	18
4.4 ELECTRICAL DATA	18
4.5 MCA/MOP DATA OF ELECTRIC HEAT KIT	19
5.0 AIRFLOW PERFORMANCE	20
6.0 REFRIGERANT CONNECTIONS	21
6.1 CONDENSATE DRAIN TUBING	21
7.0 AIR FILTER (NOT FACTORY-INSTALLED)	21
8.0 FILTER INSTALLATION DIMENSIONS	22
9.0 WIRING DIAGRAM	23
10.0 LOW VOLTAGE WIRES CONNECTIONS WITH THERMOSTAT	26
11.0 ELECTRIC WIRING GAUGE	28

1.1 Key to Symbols

Warnings

In warnings, signal words at the beginning of a warning are used to indicate the type and seriousness of the ensuing risk if measures for minimizing danger are not taken.

The following keywords are defined and used in this document :

 DANGER	
DANGER	Indicates a dangerous situation which, if not avoided will lead to death or serious injury
 WARNING	
WARNING	Indicates a dangerous situation which, if not avoided may lead to death or serious injury
 CAUTION	
CAUTION	Indicates a dangerous situation which, if not avoided may cause mild to moderate injury
 NOTE	
NOTE	Used to deal with behaviors unrelated to personal injury

Important information



This symbol represents important information that is not dangerous to people or property

1.2 Explanation of Symbols Displayed on the Unit





	Refrigerant Safety Group A2L	DANGER	This symbol shows that this appliance uses a mild flammable refrigerant. If the refrigerant is leaked and exposed to an external ignition source, there is a risk of fire.
		WARNING	This symbol shows that the appliance shall be installed, operated and stored in a room with a floor area not less than the minimum room area.
		CAUTION	This symbol shows that the operation manual should be read carefully.
		CAUTION	This symbol shows that a service personnel should be handling this equipment with reference to the installation manual.
		CAUTION	This symbol shows that information is available such as the operating manual or installation manual.

Table 1

This document is customer property and is to remain with this unit.
 These instructions do not cover all the different variations systems nor does it provide for every possible contingency to be met in connection with installation.
 All phases of this installation must comply with NATIONAL STATE AND LOCAL CODES. If additional information is required please contact your local distributor.

1.3 SAFETY

⚠ WARNING

Disconnect all power to unit before installing or servicing. More than one disconnect switch may be required to de-energize the equipment.
 Hazardous voltage can cause server personal injury or death.

⚠ WARNING

If removal of the blower assembly is required , all disconnect switches supply-ing power to the equipment must be de-energized and locked (if not in sight of unit) so the field power wires can be safely removed from the blower assembly. Failure to do so can cause electrical shock resulting in personal injuring or death.

⚠ WARNING

Because of possible damage to equipment or personal injury, installation, service, and maintenance should be performed by a trained, qualified service personnel. Consumer service is recommended only for filter cleaning/ replacement. Never operate the unit with the access panels removed.

⚠ WARNING

These instructions are intended as an aid to qualified, licensed service personnel for proper installation, adjustment and operation of this unit. Read these instructions thoroughly before attempting installation or operation. Failure to follow these instructions may result in improper installation, adjust-ment, service or maintenance possibly resulting in fire, electrical shock, prop-erty damage, personal injury or death.

⚠ WARNING

The unit must be permanently grounded. Failure to do so can result in electrical shock causing personal injury or death.

⚠ WARNING

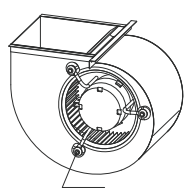

BLOWER MOTOR SHIPPING BOLT

Make sure the blower motor support is tight (3-motor mount bolts) then check to see if wheel is secured to motor shaft before operating unit.

Fig.1 Checking motor fix status

⚠ WARNING

PROPOSITION 65: This appliance contains fiberglass insulation. Respirable particles of fiberglass are known to State of California to cause cancer.
 All manufacturer products meet current federal OSHA Guidelines for safety. California Proposition 65 warnings are required for certain products, which are not covered by the OSHA standards.
 California's Proposition 65 requires warnings for products sold in California that contain or produce any of over 600 listed chemicals known to the State of California to cause cancer or birth defects such as fiberglass insulation, lead in brass, and combustion products from natural gas.
 All "new equipment" shipped for sale in California will have labels stating that the product contains and / or produces Proposition 65 chemicals. Although we have not changed our processes, having the same label on all our product facilitates manufacturing and shipping.
 We cannot always know "when, or if" products will be sold in the California market.
 You may receive inquiries from customers about chemicals found in, or produced by, some of our heating and air-conditioning equipment, or found in natural gas used with some of our products. Listed below are those chemicals and substances commonly associated with similar equipment in our industry and other manufacturers.

- Glass Wool (Fiberglass) Insulation
- Carbon Monoxide (CO).
- Formaldehyde
- Benzene

More details are available at the Websites for OSHA (Occupational Safety and Health Administration), at www.osha.gov and the State of California's OEHHA (Office of Environmental Health Hazard Assessment), at www.oehha.org. Consumer education is important since the chemicals and substances on the list are found in our daily lives. Most consumers are aware that products present safety and health risks, when improperly used, handled and maintained.

⚠ WARNING

The first 36 inches of supply air plenum and ductwork must be constructed of sheet metal as required by NFPA 90B. The supply air plenum or duct must have a solid sheet metal bottom directly under the unit with no openings, registers or flexible air ducts located in it. If flexible supply air ducts are used they may be located only in the vertical walls of rectangular plenum, a minimum of 6 inches from the solid bottom. Metal plenum or duct may be connected to the combustible floor base, if not, it must be connected to the unit supply duct exposed to the supply air opening from the down flow unit. Exposing combustible (non-metal) material to the supply opening of a down-flow unit can cause a fire resulting in property damage, personal injury or death. Exception warning to downflow:
 Installations on concrete floor slab with supply air plenum and ductwork completely encased must be not less than 2 inches of concrete (See NFPA 90A).

WARNING

Only use this unit in a well-ventilated area and ensure unit's airflow inlet and outlet would not be impeded by obstructions. Do not use this unit in the following locations:

- Locations with mineral oil.
- Locations with saline atmospheres, such as seaside location.
- Locations with sulphurous atmospheres, such as near natural hot springs.
- Where high voltage electricity is present, such as in certain industrial locations.
- On vehicles or vessels, such as trucks or ferry boats.
- Where exposure to oily or very humid air may occur, such as kitchens.
- In proximity to sources of electromagnetic radiation, such as high-frequency transmitters or other high strength radiation devices.

WARNING

- Do not use means to accelerate the defrosting process or to clean, other than those recommended by the manufacturer.
 - The appliance shall be stored in a room that does not have continuously operating ignition sources (for example: open flames, an operating gas appliance or an operating electric heater).
 - Do not pierce or burn the unit.
- Be aware that refrigerants may not contain an odour.
- If refrigerant gas leaks during installation, ventilate the area immediately.
 - Comply with national gas regulations.

WARNING

When repairing the refrigerating system, comply with the following precautions prior to conducting work on the system:

- Work shall be undertaken according to controlled procedures to minimize the risk of the presence of flammable gases or vapors while the work is being performed.
- All maintenance staff and others working in the local area shall be instructed on the nature of work being carried out. Work in confined spaces shall be avoided.
- The area shall be checked with an appropriate refrigerant detector prior to and during work, to ensure the technician is aware of potentially toxic or flammable environment. Ensure that the leak detection equipment being used is suitable for use with all applicable refrigerants, i.e., non-sparking, adequately sealed or intrinsically safe.
- If any hot work is to be conducted on the refrigerating equipment or any associated parts, appropriate fire extinguishing equipment shall be available and easily accessible. Have a dry powder or CO₂ fire extinguisher adjacent to the charging area.
- When carrying out work in relation to a refrigerating system that involves exposing any pipe work, no sources of ignition shall be used in such a manner that it may lead to the risk of fire or explosion. All possible ignition sources, including cigarette smoking, should be kept sufficiently far away from the site of installation, repair, or removal and disposal of the unit, during which refrigerant can possibly be released into the surrounding space. Prior to beginning

work, the area around the equipment is to be surveyed to make sure that there are no flammable hazards or ignition risks. "No Smoking" signs shall be clearly displayed.

WARNING

This appliance is not intended for use by people (including children) with reduced physical, sensory or mental capabilities, or people who lack experience and knowledge, unless they are supervised or have been given instructions concerning the use of the appliance by a person responsible for their safety.

Children should be supervised to ensure that they do not play with the appliance.

Any person who is involved with working on or opening a refrigerant circuit should hold a current valid certificate from an industry-accredited assessment authority, which authorizes their competence to handle refrigerants safely in accordance with an industry recognized assessment credential.

Servicing shall only be performed as recommended by the equipment manufacturer.

Maintenance and repair requiring the assistance of other skilled personnel shall be carried out under the supervision of a person competent in the use of flammable refrigerants.

Prior to beginning work on systems containing flammable refrigerants, safety checks are necessary to minimize the risk of ignition.

WARNING

Ensure that the area is in the open or that it is adequately ventilated before opening the system or conducting any hot work. A degree of ventilation shall continue during the period that the work is carried out. The ventilation should safely disperse any released refrigerant and preferably expel it externally into the surroundings.

Where electrical components are being changed, they shall be fitted according to their purpose and to the correct specification. At all times the manufacturer's maintenance and service guidelines shall be followed. If in doubt, consult the manufacturer's technical department for assistance. The following checks shall be applied to installations using flammable refrigerants:

- The actual refrigerant charge is in accordance with the room size within which the refrigerant containing parts are installed.
- The ventilation machinery and outlets are operating adequately and are not obstructed.
- If an indirect refrigerating circuit is being used, the secondary circuit shall be checked for the presence of refrigerant.
- Equipment marking must remain visible and legible. Markings and signs that are illegible shall be corrected.

⚠ WARNING

Refrigerating pipe or components are installed in a position where they are unlikely to be exposed to any substances which may corrode refrigerant containing components, unless the components are constructed of materials that are inherently resistant to corrosion or are suitably protected against corrosion.

Repair and maintenance of electrical components shall include initial safety checks and component inspection procedures. If a fault exists that could compromise safety, the no electrical supply shall be connected to the circuit until the fault has been dealt with.

- That there is continuity of grounding.
- That capacitors are discharged: this shall be done in a safe manner to avoid the possibility of sparking.
- That no live electrical components and wiring are exposed while charging, recovering or purging the system.

⚠ WARNING

Flammable refrigerant*

Sealed electrical components shall be replaced.

Intrinsically safe components must be replaced.

Check that cabling will not be subject to wear, corrosion, excessive pressure, vibration, sharp edges or any other adverse environmental effects. The check shall also take into account the effects of aging or continual vibration from sources such as compressors or fans.

Under no circumstances shall potential sources of ignition be used while searching for or detection of refrigerant leaks. A halide torch (or any other detector using a naked flame) shall not be used.

Electronic leak detectors may be used to detect refrigerant leaks but, in the case of flammable refrigerants, the sensitivity may not be adequate, or may need recalibration. (Detection equipment shall be calibrated in a refrigerant-free area.) Ensure that the detector is not a potential source of ignition and is suitable for the refrigerant used. Leak detection equipment shall be set at a percentage of the LFL of the refrigerant and shall be calibrated for the refrigerant employed, and the appropriate percentage of gas (25% maximum) is confirmed.

If a leak is suspected, all naked flames shall be removed/extinguished.

If a leakage of refrigerant which requires brazing is found, all of the refrigerant shall be recovered from the system, or isolated (by means of shut off valves) in a part of the system remote from the leak.

Leak detection fluids are also suitable for use with most refrigerants but the use of detergents containing chlorine shall be avoided as the chlorine may react with the refrigerant and corrode the copper pipe-work.

Examples of leak detection fluids are:

- bubble method •

When breaking into the refrigerant circuit to make repairs - or for any other purpose conventional procedures shall be used. However, for flammable refrigerants it is important that best practice be followed, since flammability is a consideration.

The following procedure shall be adhered to:

- safely remove refrigerant following local and national regulations.
- evacuate.
- purge the circuit with inert gas.
- evacuate.
- continuously flush or purge with inert gas when using flame to open circuit.
- open the circuit.

The refrigerant charge shall be recovered into the correct recovery cylinders if venting is not allowed by local and national codes. For appliances containing flammable refrigerants, the system shall be purged with oxygen-free nitrogen to render the appliance safe for flammable refrigerants. This process might need to be repeated several times. Compressed air or oxygen shall not be used for purging refrigerant systems.

For appliances containing flammable refrigerants, refrigerants purging shall be achieved by breaking the vacuum in the system with oxygen-free nitrogen and continuing to fill until the working pressure is achieved, then venting to atmosphere, and finally pulling down to a vacuum. This process shall be repeated until no refrigerant is within the system. When the final oxygen-free nitrogen charge is used, the system shall be vented down to atmospheric pressure to enable work to take place.

The outlet for the vacuum pump shall not be close to any potential ignition sources, and ventilation shall be available.

Ensure that contamination of different refrigerants does not occur when using charging equipment. Hoses or lines shall be as short as possible to minimize the amount of refrigerant they contain.

Cylinders shall be kept upright. Ensure that the refrigeration system is grounded prior to charging the system with refrigerant.

Label the system when charging is complete (if it is not already labeled).

Take extreme care not to overfill the refrigeration system.

Prior to recharging the system, it shall be pressure-tested with the appropriate purging gas. The system shall be leak-tested on completion of charging but prior to commissioning. A follow up leak test shall be carried out prior to leaving the site.

Before carrying out this procedure, it is essential that the technician is completely familiar with the equipment and all its detail. It is recommended that all refrigerants are recovered safely. Prior to the task being carried out, an oil and refrigerant sample shall be taken in case analysis is required prior to reuse of reclaimed refrigerant. It is essential that electrical power is available before the task is commenced.

- Isolate system electrically.
- Become familiar with the equipment and its operation.
- Before attempting the procedure ensure that:
 - mechanical handling equipment is available, if required, for handling refrigerant cylinders;
 - all personal protective equipment is available and used correctly;

- the recovery process is supervised at all times by a competent person;
- recovery equipment and cylinders conform to the appropriate standards.
- Pump down refrigerant system, if possible.
- If a vacuum is not possible, make a manifold so that refrigerant can be removed from various parts of the system.
- Make sure that the cylinder is situated on the scales before recovery takes place.
- Start the recovery machine and operate it in accordance with the manufacturer's instructions.
- Do not overfill cylinders. (No more than 80% volume liquid charge).
- Do not exceed the maximum working pressure of the cylinder, even temporarily.
- When the cylinders have been filled correctly and the process has been completed, make sure that the cylinders and the equipment are removed from site promptly and all isolation valves on the equipment are closed off.
- Recovered refrigerant shall not be charged into another refrigeration system unless it has been cleaned and checked.

Equipment shall be labeled stating that it has been de-commissioned and emptied of refrigerant. The label shall be dated and signed.

Ensure that there are labels on the equipment stating that the equipment contains flammable refrigerant.

When removing refrigerant from a system, either for servicing or decommissioning, it is recommended that all refrigerants are removed safely.

When transferring refrigerant into cylinders, ensure that only appropriate refrigerant recovery cylinders are employed. Ensure that the correct number of cylinders for holding the total system charge is available. All cylinders to be used are designated for the recovered refrigerant and labelled for that refrigerant (i.e. special cylinders for the recovery of refrigerant). Cylinders shall be complete with pressure-relief valve and associated shut-off valves in good working order. Empty recovery cylinders are evacuated and, if possible, cooled before recovery occurs.

The recovery equipment must be in good working order and come with a set of instructions for proper usage. Furthermore, the equipment should be suitable for safely recovering flammable refrigerants. If in doubt, the manufacturer should be consulted. In addition, a set of calibrated weighing scales shall be available and in good working order. Hoses shall be complete with leak-free disconnect couplings and in good condition.

The recovered refrigerant shall be processed according to local legislation in the correct recovery cylinder, and the relevant waste transfer note arranged. Do not mix refrigerants in recovery units and especially not in cylinders.

If compressors or compressor oils are to be removed, ensure that they have been evacuated to an acceptable level to be certain that flammable refrigerant does not remain within the lubricant. The compressor body shall not be heated by an open flame or other ignition sources to accelerate this process. When oil is drained from a system, it shall be carried out safely.

Do not use the air conditioner for other purposes. In order to avoid any quality deterioration, do not use the unit for the cooling of precision instruments, food, plants, animals or works of art. Before cleaning, be sure to stop the operation, turn the breaker off or unplug the supply cord. Otherwise, electric shock and injury may occur.

In order to avoid electric shock or fire, make sure that a ground leak detector is installed.

Never touch the air outlet or the horizontal blades while the swing flap is in operation. Your fingers may be caught or the unit may break down.

Never put any objects into the air inlet or outlet.

Objects touching the fan at high speed can be dangerous.

Never inspect or service the unit by yourself.

Ask a qualified service person to perform this task.

If electrical appliances are disposed of in landfills or dumps, hazardous substances can leak into the groundwater and get into the food chain, harming your health and well-being.

Do not dispose of this product as unsorted municipal waste. This waste should be collected separately for special treatment. Do not dispose of electrical appliances as unsorted municipal waste. Use separate collection facilities. Contact your local government for information regarding the connection systems available.

To prevent refrigerant leak, contact your dealer.

When the system is installed and operated in a small room, it is required to maintain the concentration of the refrigerant below the limit, in case a leak occurs. Otherwise, oxygen in the room may be affected, resulting in a serious accident.

The refrigerant in the air conditioner is safe and normally does not leak.

If the refrigerant leaks into the room and comes into contact with the fire of a burner, a heater or a cooker, a harmful gas could be released.

Turn off any combustible heating devices, ventilate the room, and contact the dealer from whom you purchased the unit.

Do not use the air conditioner until a service person confirms that the refrigerant leak is repaired.

Keep ventilation openings clear of obstruction.

WARNING

Be sure the air conditioner is grounded.

In order to avoid electric shock, make sure that the unit is grounded and that the ground wire is not connected to a gas or water pipe, lightning conductor or telephone ground wire.

Do not operate the air conditioner with wet hands. An electric shock may happen.

Do not touch the heat exchanger fins. These fins are sharp and could cut you.

WARNING

To avoid oxygen deficiency, ventilate the room sufficiently if equipment with a burner is used together with the air conditioner.

Arrange the drain hose to ensure smooth drainage. Incomplete drainage may cause wetting of the building, furniture, etc.

Never touch the internal parts of the controller.

Do not remove the blower access panel. Some parts inside are dangerous to touch, and machine issues may occur.

Attention is drawn to the fact that additional transportation regulations may exist with respect to the equipment containing a flammable gas. The maximum number of pieces of equipment or the configuration of the equipment permitted to be transported together will be determined by the applicable transport regulations.

Signs for similar appliances used in a work area are generally addressed by local regulations and give the minimum requirements for the provision of safety and/or health signs for a work location.

All required signs are to be maintained and employers should ensure that employees receive suitable and sufficient instruction and

training on the meaning of appropriate safety signs and the actions that need to be taken in connection with these signs.

The effectiveness of signs should not be diminished by too many signs being placed together.

Any pictograms used should be as simple as possible and contain only essential details.

The storage of the appliance should be in accordance with the applicable regulations or instructions, whichever is more stringent.

Storage package protection should be constructed such a way that mechanical damage to the equipment inside the package will not cause a leak of the refrigerant charge.

The maximum number of pieces of equipment permitted to be stored together will be determined by local regulations.

Do not operate the air conditioner when using a room fumigation - type insecticide. Failure to observe this precaution could cause the chemicals to become deposited in the unit, which could endanger the health of those who are hypersensitive to chemicals. It may also cause the refrigerant sensor to alarm.

Do not place appliances which produce open flames in places exposed to the air flow from the unit or under the indoor unit. It may cause incomplete combustion or deformation of the unit due to the heat.

Do not install the air conditioner in a location where flammable gas may leak out. If the gas leaks out and stays around the air conditioner, a fire may break out.

The appliance uses R454B refrigerant



2.0 GENERAL

The unit can be positioned for bottom return air in the up flow position, left and right return in the horizontal position, top return in down flow position.

This Air Handler provides the flexibility for installation in any up flow or down flow horizontal application. The direct drive motors provides a selection of air volume to match any application. 3-Speed motors provide selections of air flow to meet desired applications.

Top and side power and control wiring, accessible screw terminals for control wiring all combine to make the installation easy, and minimize installation cost. Please contact your local distributor. See Fig.6.

Do not install unit in an area where flammable materials are present due to the risk of an explosion resulting in serious injury or death.

The appliance is only intended to supply conditioned air to one room.

If the supporting structural members are not strong enough to take the unit's weight, the unit could fall out of place and cause serious injury.

If a return-air duct is not installed, carefully select the place and method of product installation so that air flow into the product will not be blocked.

The unit should be installed in a level position to ensure proper condensation drainage. Up to an additional 1/4" rise over the width or depth of the unit is allowed to create additional sloping towards the drain. Unit must be positioned between level and 1/4" rise, sloping toward the drain connections.

Install the indoor and outdoor unit, power supply wiring and connecting wires at least 3.5 ft. away from televisions or radios in order to prevent image interference or noise. To ensure the proper installation, select a solid and level site. Ensure enough space maintained for installation and maintenance. See Fig.2 and Fig.3.

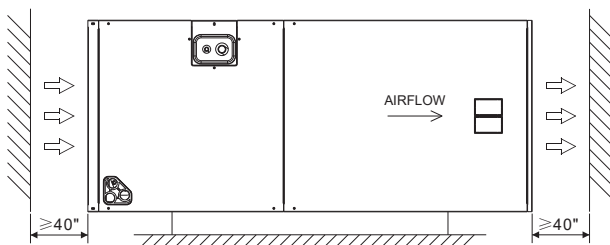

Fig.2 Clearances in the horizontal position

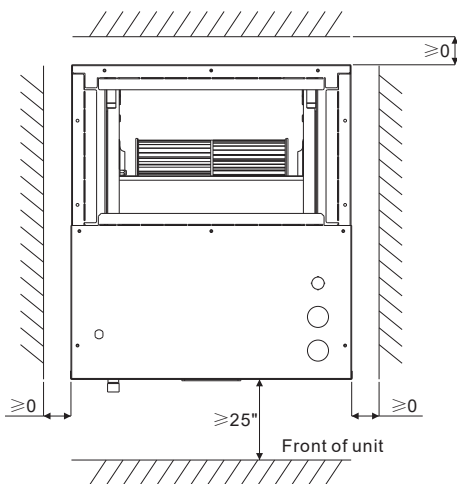

Fig.3 Clearances in the vertical position

When the unit is installed in a hot and humid place, If the humidity inside the installation space might exceed 86°F and RH 80%, it is recommended to insulate the cabinet exterior.

Use glass wool or polyethylene foam as insulation so that the thickness is more than 2 in. and fits inside the installation space opening.

Respectively, condensation may form on the surface of the insulation.

Be sure to use insulation that is designed for use with HVAC Systems. Condensation may form on the product during cool operation. It is also recommended to use second drain pan and secure the unit firmly to prevent it from falling. see Fig.4 and Fig.5 .

WARNING

Supply duct is intended to handle conditioned air for circulation through a duct supplying only one room. Room space may be partitioned into rooms within the same unit, but supply air is not to be delivered to any other rooms.

WARNING

Supply duct is intended to handle conditioned air for circulation through a duct supplying only one room. Room space may be partitioned into rooms within the same unit, but supply air is not to be delivered to any other rooms.

2.1 Refrigerant Sensor

R454B refrigerant leakage sensor is configured for the indoor unit. To meet different installation scenarios, the refrigerant sensor has two installation positions. The factory set of the refrigerant sensor is applied to the vertical upflow and horizontal right. The refrigerant sensor needs to be relocated for vertical downflow and horizontal left. Before installing the indoor unit, check whether the refrigerant sensor is correctly installed according to Fig 8.

WARNING

The refrigerant leakage sensor can only use the factory model or the specified model indicated in the corresponding manual.

The R454B refrigerant leakage sensor must be used to activate the refrigerant shut-off device, the alarm device, incorporated circulation airflow or other emergency controls, which shall give an electrical signal at a predetermined alarm set point in response to leaked refrigerant.

The location of leakage sensors shall be chosen in relation to the different installation scenarios. Please refer to the indoor unit installation manual for specific requirements.

The installation of the refrigerant leakage sensor shall allow access for checking, repair or replacement by an authorized person.

The refrigerant leakage sensor shall be installed so its function can be verified easily.

The refrigerant leakage sensor shall be protected to prevent tampering or unauthorized resetting of the pre-set value.

To be effective, the refrigerant leakage sensor must be electrically powered at all times after installation, other than when servicing.

If the refrigerant leakage sensor detects a refrigerant leak, the fan will keep running, the compressor will stop and electric heater will be shut off. You should immediately leave the leak area and notify a professional for handling.

⚠ WARNING

System will return when refrigerant is no longer detected in 5 minutes.

The service life of the refrigerant sensor is 15 years, and it should be replaced after the service life.

To ensure the detection accuracy of the refrigerant sensor, it is recommended to blow dust off the surface of the refrigerant sensor after it is used for a long time.

⚠ WARNING

These instructions are exclusively intended for qualified contractors and authorized installers.

Work on the refrigerant circuit with flammable refrigerant in safety group A2L may only be carried out by authorized contractors. These heating contractors must be trained in accordance with UL 60335-2-40, Section HH. The certificate of competence from an industry accredited body is required.

Work on electrical equipment may only be carried out by a qualified electrician.

Before initial commissioning, all safety – related points must be checked by the particular certified heating contractors. The system must be commissioned by the system installer or a qualified person authorized by the installer.

For installation of the indoor unit, refer to the corresponding installation and operation manual. If an indoor unit is installed in an unventilated area, the area shall be so constructed that should any refrigerant leak, it will not stagnate so as to create a fire or explosion hazard.

The appliance shall be stored so as to prevent mechanical damage from occurring.

Do not stack combustible materials on the surface of the indoor unit.

⚠ WARNING

LEAK DETECTION SYSTEM installed on indoor unit. Unit must be powered on except for during servicing.

⚠ WARNING

Ensure the apparatus is mounted securely.

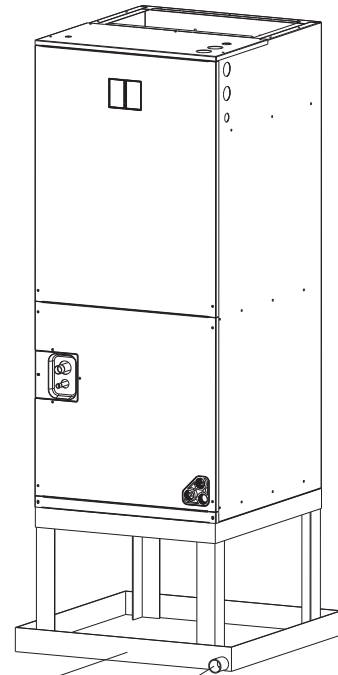

Second drain pan Drain piping
Fig.4 Installed vertically

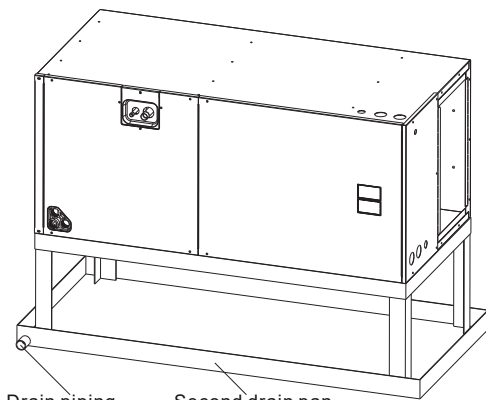

Drain piping Second drain pan
Fig.5 Installed horizontally

The R454B refrigerant leakage sensor is configured for the indoor unit. The fan operation can be initiated by the R454B refrigerant sensor, ensuring that it meets the required circulation airflow requirements. The allowed maximum refrigerant charge (M_{max}) and the required minimum room area (A_{min}) can be determined according to Table 5 and Table 6.

2.2 UNIT DIMENSIONS

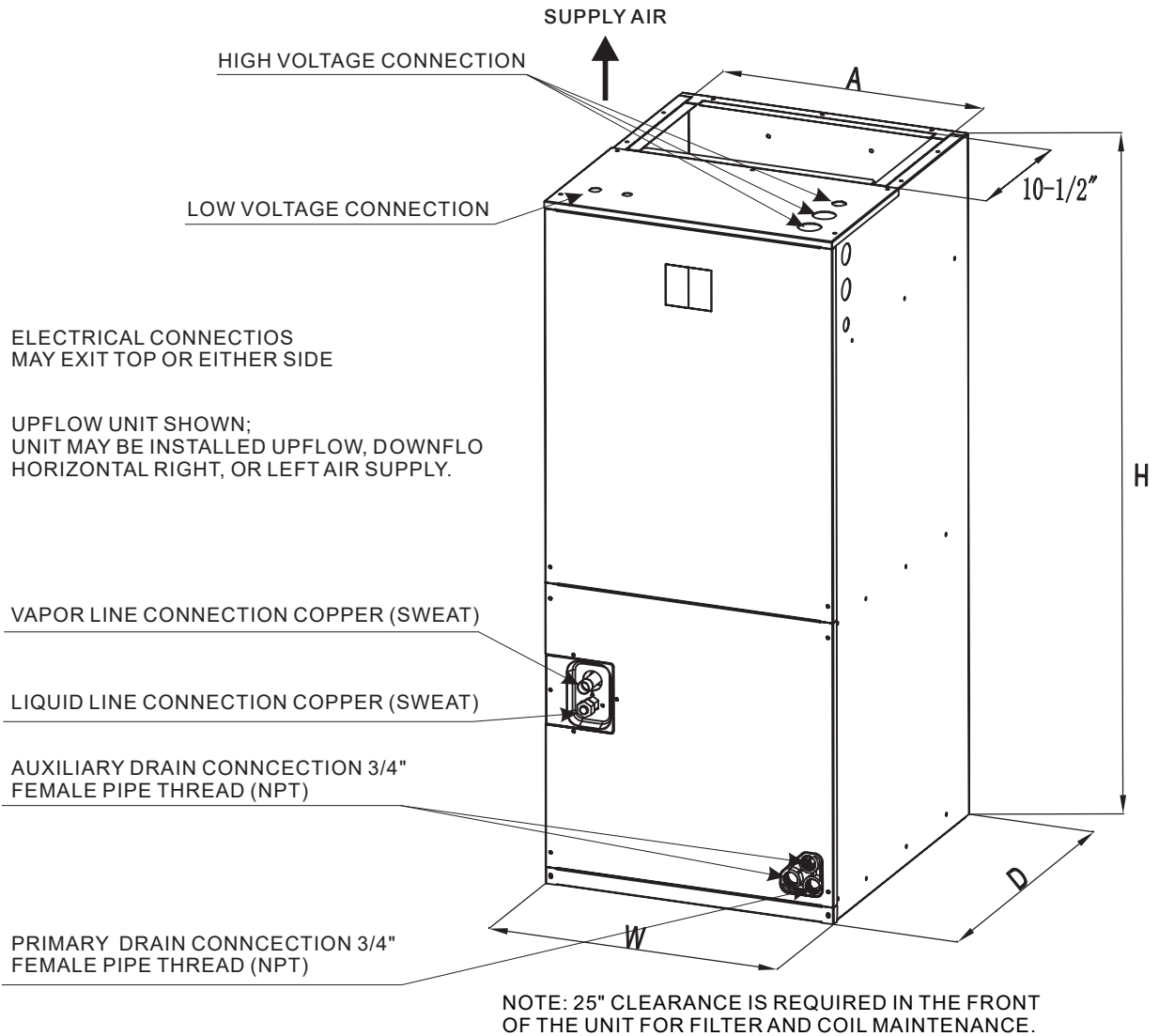

Fig.7 DIMENSIONS

DIMENSIONAL DATA

MODEL SIZE	Dimensions inch[mm]				
	UNIT HEIGHT "H" IN. [mm]	UNIT WIDTH "W" IN.[mm]	UNIT LENGTH "D" IN. [mm]	SUPPLY DUCT "A" IN[mm]	LIQUID LINE/ VAPOR LINE IN
18K	45-3/4"[1162]	19-5/8"[500]	22"[560]	17-7/8"[454]	3/8" / 3/4"
24K	45-3/4"[1162]	19-5/8"[500]	22"[560]	17-7/8"[454]	3/8" / 3/4"
30K	45-3/4"[1162]	19-5/8"[500]	22"[560]	17-7/8"[454]	3/8" / 3/4"
36K	45-3/4"[1162]	19-5/8"[500]	22"[560]	17-7/8"[454]	3/8" / 3/4"
42K	45-3/4"[1162]	19-5/8"[500]	22"[560]	17-7/8"[454]	3/8" / 3/4"
48K	53-1/8"[1350]	22"[560]	24-1/2"[623]	19-1/2"[496]	3/8" / 7/8"
60K	53-1/8"[1350]	22"[560]	24-1/2"[623]	19-1/2"[496]	3/8" / 7/8"

Table 2

2.3 Parts Introduction

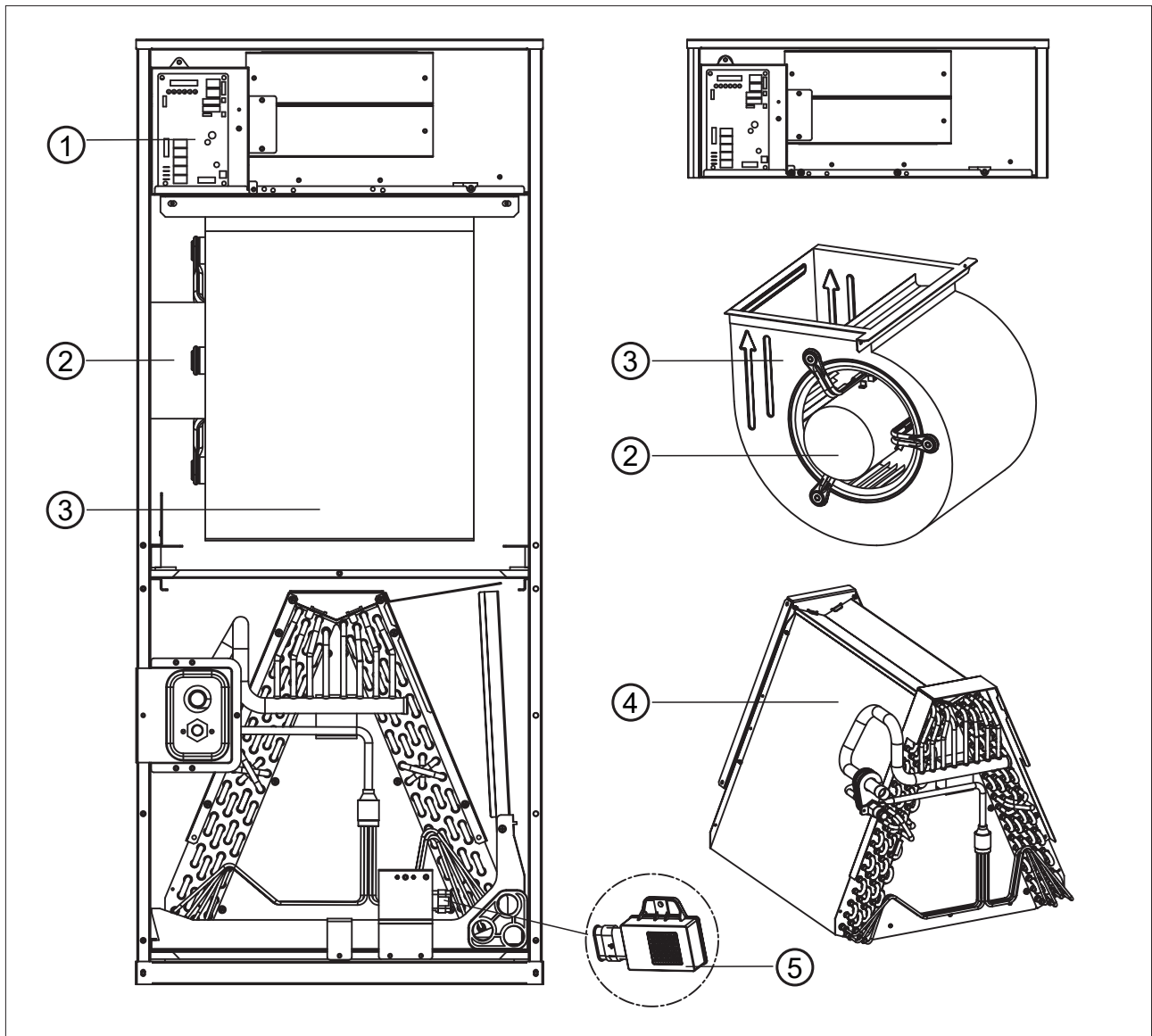

Fig.8

Number	①	②	③	④	⑤
Parts	Control Board	AC Motor	Blower	AL-Evaporator	R454B Refrigerant Sensor

Table 3

3.0 APPLICATIONS

3.1 VERTICAL UPFLOW

- 1) Vertical Upflow configuration is the factory set on all models (see Fig 9)
- 2) If a side return air opening is required, field fabricate a return air plenum with an opening large enough to supply unit and strong enough to support unit weight.
- 3) If return air is to be ducted, install duct flush with floor. Use fireproof resilient gasket 1/8 to 1/4 in. thick between the ducts, unit and floor. Set unit on floor over opening.

IMPORTANT NOTE

Torque applied to drain connections should not exceed 15. ft.lbs. (see Fig.8&9)

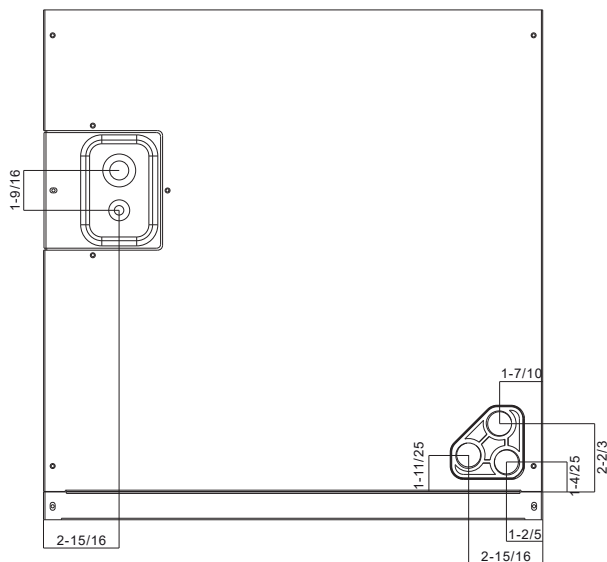

Fig.9 DIMENSIONS FOR FRONT CONNECT COIL

3.2 Vertical Downflow

Conversion to Vertical Downflow:

A vertical upflow unit may be converted to vertical downflow. See Fig.10.

1. Remove the coil access panel
2. Remove the refrigerant leak detection sensor and indoor coil.
3. Reinstall indoor coil 180 degrees from original position.
4. Reinstall the refrigerant sensor at the location shown in Fig.11.

CAUTION

The refrigerant leak detection sensor needs to be relocated in this application. Please follow the steps in the next page.

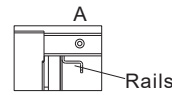

ENSURE THE RETAINING CHANNEL IS FULLY ENGAGED WITH THE COIL RAIL.

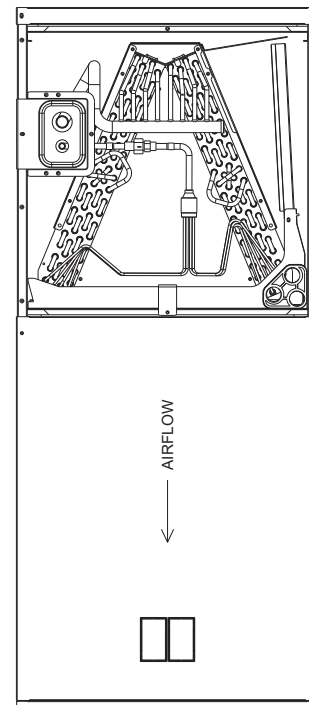
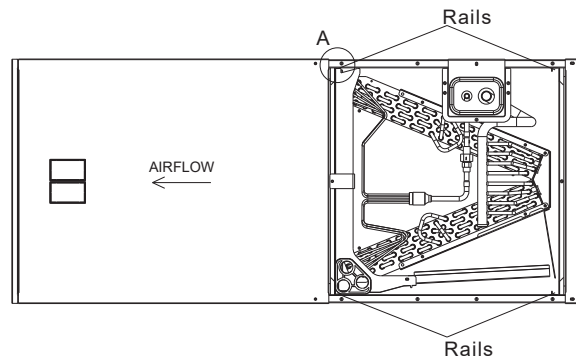

Fig.10 VERTICAL DOWNFLOW & HORIZONTAL LEFT APPLICATIONS

3.3 HORIZONTAL

Horizontal right is the default factory configuration for the units. Horizontal left isn't the default factory configuration for the units. Conversion to Horizontal left: A vertical upflow unit may be converted to horizontal left by removing indoor coil assembly and reinstalling coil as shown for left hand air supply.

- 1) Rotate unit into the downflow position, with the coil compartment on top and the blower compartment on bottom. See Fig. 10.
- 2) Reinstall the indoor coil 180° from original position. Ensure the retaining channel is fully engaged with the coil rail. See Fig. 10.
- 3) Secondary drain pan kits are recommended when the unit is configured for the horizontal position over a finished ceiling and/or living space.

Steps for Changing Cabinet Orientation to Vertical Downflow or Horizontal Left Orientation

1. Remove the screws, upper side plate, lower side plate, filter cover plate, and support strip, and disconnect the refrigerant sensor on the control board(Fig. 11, Step1).
2. Cut off the zipper buckle of the refrigerant leakage sensor harness, and then unscrew the screws from the support strip and the refrigerant leakage sensor mounting plate to remove the sensor(Fig. 11, Step2).
3. Reinstall the indoor coil 180 ° from its original position and install the refrigerant leakage sensor in the position shown in the diagram(Fig. 11, Step3).
4. Replace the wiring harness in the correct position and secure it in place. Insert the refrigerant sensor cable back into the control board(Fig. 11, Step 3).
5. Reinstall the upper side panel and other components and fix them with screws.

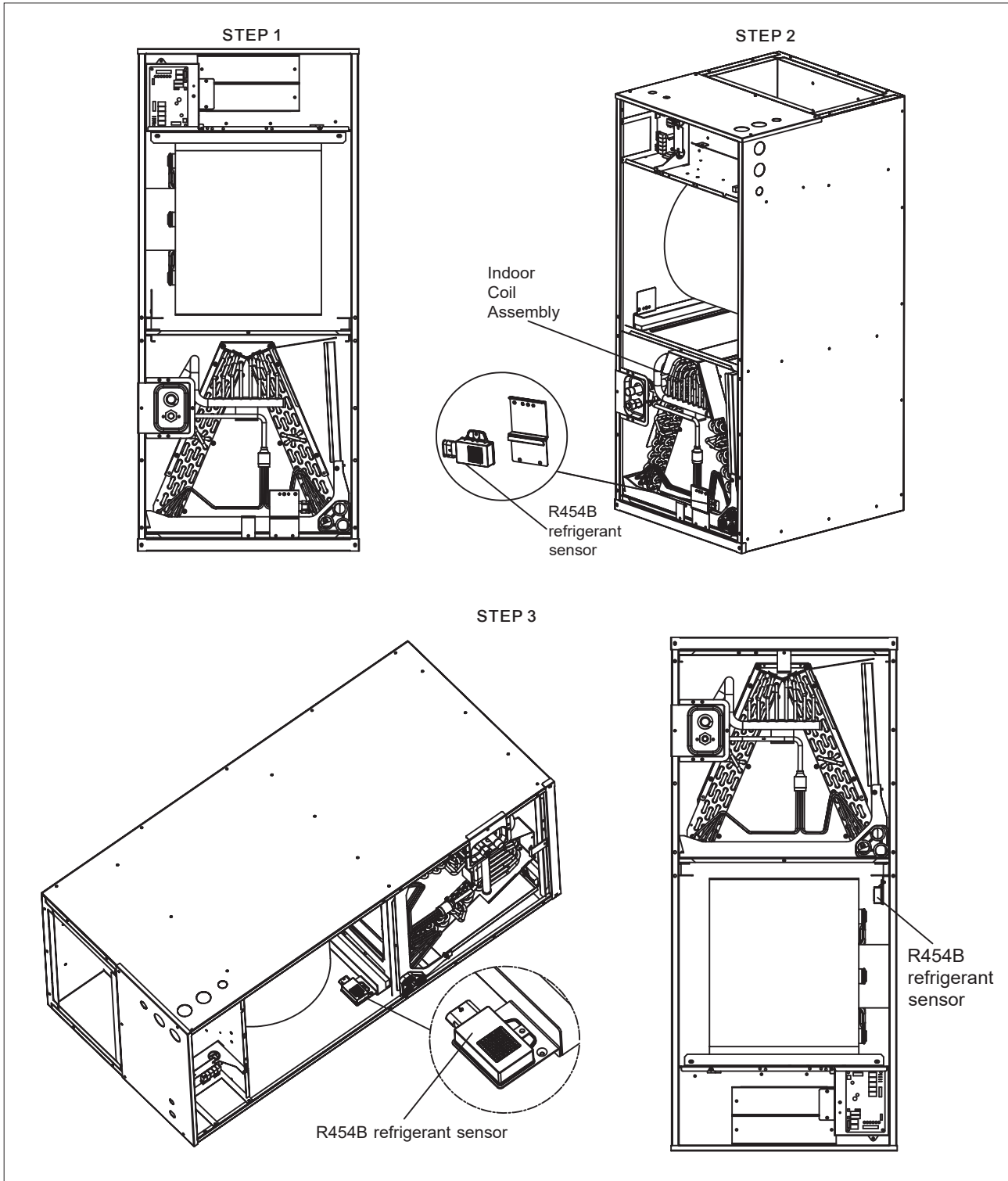
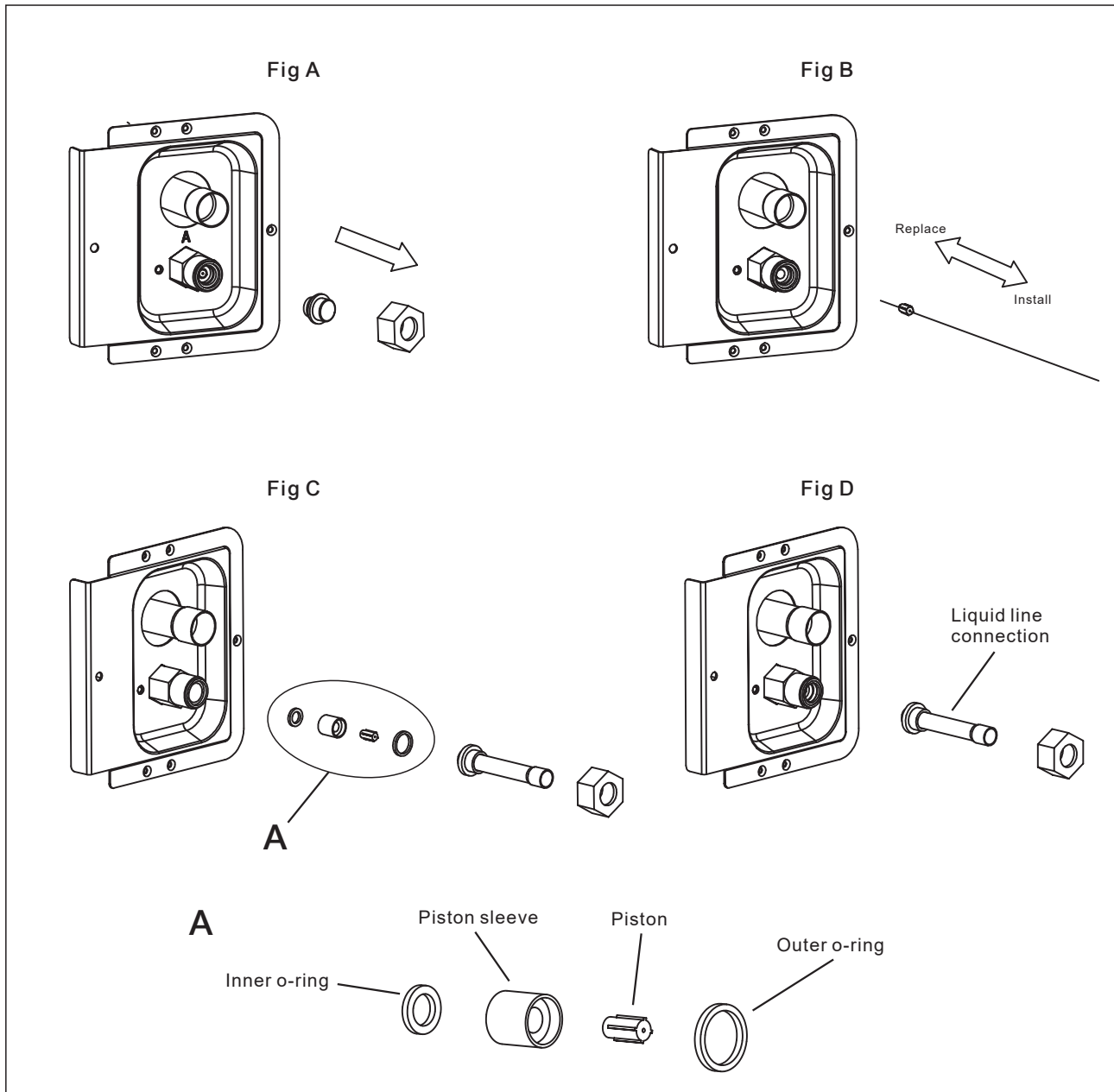

Fig. 11 Vertical downflow & horizontal left applications conversion

3.4 Coil Piston Replace and Installation

1. Use a wrench to loosen the nut and pull out the rubber plug(Fig A).
2. Replacement installation method of valve core as shown in Fig B.
3. Take out the inner O-ring, piston sleeve, piston, outer O-ring, liquid line connection from the accessories, and install them in sequence as shown in Fig C. Ensure the direction is correct. (Note: The inner O-ring is installed together with the piston sleeve.)
4. Re-attach the liquid line with the nut, and tighten it to 1/6th turn past hand-tighten(Fig D).



3.5 Refrigerant Charge and Room Area Limitations

In UL/CSA 60335-2-40, R454B refrigerant is classified as class A2L, which is mildly flammable. Therefore, R454B refrigerant is suitable for systems needing additional refrigerant charge and which will limit the area of the rooms being served by the system.

Similarly, the total amount of refrigerant in the system shall be less than or equal to the allowable maximum refrigerant charge. The allowable maximum refrigerant charge depends on the area of the rooms being served by the system.

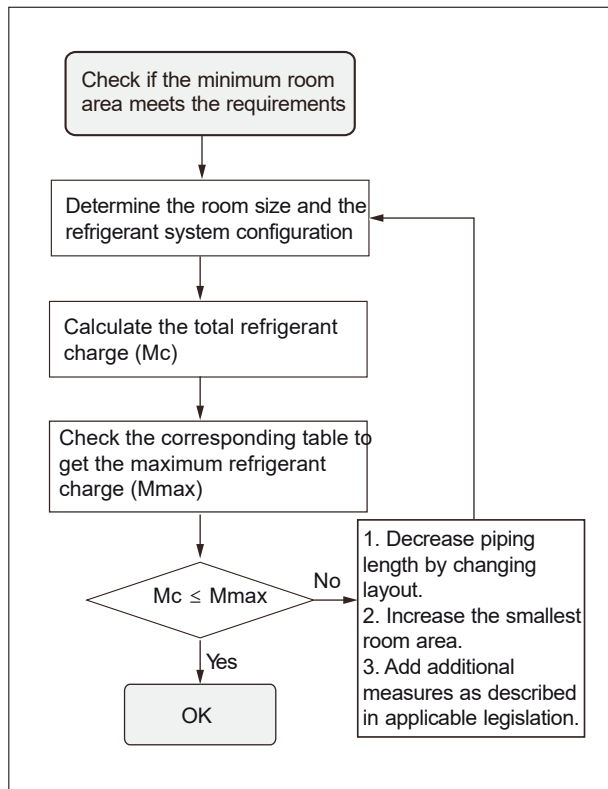

Fig.12

NOTE

The nouns in this section are explained as follows:

Mc: The actual refrigerant charge in the system.

A: the actual room area where the appliance is installed.

Amin: The required minimum room area.

Mmax: The allowable maximum refrigerant charge in a room.

Qmin : The minimum circulation airflow.

Anvmin• The minimum opening area for connected rooms.

TAmin• The total area of the conditioned space (For appliances serving one or more rooms with an air duct system).

TA• The total area of the conditioned space connected by air ducts.

3.6 The room area calculation requirements

CAUTION

The space considered shall be any space which contains refrigerant-containing parts or into which refrigerant could be released.

The room area (A) of the smallest, enclosed, occupied space shall be used in the determination of the refrigerant quantity limits.

For determination of room area (A) when used to calculate the refrigerant charge limit, the following shall apply.

The room area (A) shall be defined as the room area enclosed by the projection to the base of the walls, partitions and doors of the space in which the appliance is installed.

Spaces connected by only drop ceilings, ductwork, or similar connections shall not be considered a single space.

Units mounted higher than 70-55/64 inches and spaces divided by partition walls that are no higher than 62-63/64 inches shall be considered a single space. Rooms on the same floor and connected by an open passageway between the spaces can be considered a single room when determining compliance to Amin, if the passageway complies with all of the following.

1. It is a permanent opening.
2. It extends to the floor.
3. It is intended for people to walk through.

The area of the connected rooms, on the same floor, connected by permanent opening in the walls and/or doors between occupied spaces, including gaps between the wall and the floor, can be considered a single room when determining compliance to Amin, provided all of the following conditions are met as Fig 13.

1.Low level opening:

- 1) The opening shall not be less than Anvmin in Table 5.
- 2) The area of any openings above 11-13/16 inches from the floor shall not be considered in determining compliance with Anvmin.
- 3) At least 50% of the opening area of Anvmin shall be below 7-7/8 inches from the floor.
- 4) The bottom of the opening is not more than 3-15/16 inches from the floor.
- 5) The opening is a permanent opening that cannot be closed.
- 6) For openings extending to the floor the height shall not be less than 25/32 inches above the surface of the floor covering.

2.High level opening:

- 1) The opening shall not be less than 50% of Anvmin in Table 5.
- 2) The opening is a permanent opening that cannot be closed.
- 3) The opening shall be at least 59 inches above the floor.
- 4) The height of the opening is not less than 25/32 inches.

3.Room size requirement:

- 1) The room into which refrigerant can leak, plus the connected adjacent room(s) shall have a total area not less than Amin. Amin is shown in Tables 7-9.
- 2) The room area in which the unit is installed shall be not less than 20% Amin. Amin is shown in Tables 7-9.

NOTE

The requirement for the second opening can be met by drop ceilings, ventilation ducts, or similar arrangements that provide an airflow path between the connected rooms.

The minimum opening for natural ventilation (A_{nmin}) in connected rooms is related to the room area (A), the actual refrigerant charge of refrigerant in the system (M_c), and the allowable MAXIMUM REFRIGERANT CHARGE in the system (M_{max}), A_{nmin} can be determined according to Table 4.

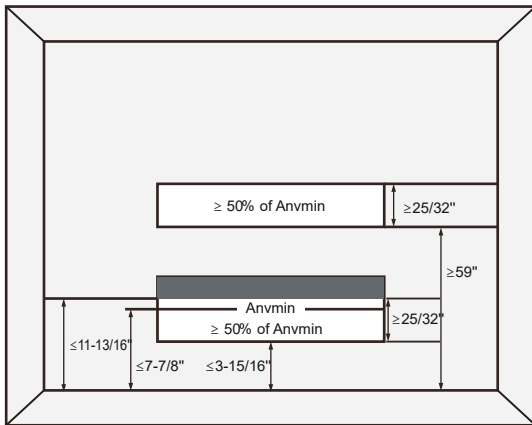

Fig.13 Opening Conditions for Connected Rooms

The minimum opening area for connected rooms

A(ft ²)	Mc(□lb□oz)		Mmax(□lb□oz)		Anvmin(ft ²)
	lb	oz	lb	oz	
100	17	3	6	10	1.3
110	17	3	7	5	1.2
120	17	3	8	0	1.1
130	17	3	8	10	1.0
140	17	3	9	5	1.0
150	17	3	10	0	0.9
160	17	3	10	10	0.8
170	17	3	11	5	0.7
180	17	3	12	0	0.6
190	17	3	12	10	0.5
200	17	3	13	5	0.5
210	17	3	14	0	0.4
220	17	3	14	10	0.3
230	17	3	15	5	0.2
240	17	3	16	0	0.1
250	17	3	16	10	0.1
260	17	3	17	5	0.0

Table 4

Note: Take the $M_c=17$ lb 3 oz as an example.

For appliances serving one or more rooms with an air duct system, The room area calculation shall be determined based on the total area of the conditioned space (TA) connected by ducts taking into consideration that the circulating airflow distributed to all the rooms by the appliance integral indoor fan will mix and dilute the leaking refrigerant before entering any room.

3.7 The allowed maximum refrigerant charge and required minimum room area

If the fan incorporated in the appliance is continuously operated or operation is initiated by a REFRIGERANT DETECTION SYSTEM with a sufficient CIRCULATION AIRFLOW rate, the allowable maximum refrigerant charge (M_{max}) and the required minimum room area (A_{min}/T_{Amin}) is shown in Table 5 and Table 6.

The allowable maximum refrigerant charge

A/TA		Mmax		A/TA		Mmax	
ft ²	m ²	lb-oz	kg	ft ²	m ²	lb-oz	kg
30	2,8	2-0	0,9	150	13,9	10-0	4,5
40	3,7	2-9	1,2	160	14,9	10-9	4,8
50	4,6	3-5	1,5	170	15,8	11-4	5,1
60	5,6	3-14	1,8	180	16,7	11-15	5,4
70	6,5	4-9	2,1	190	17,7	12-9	5,7
80	7,4	5-3	2,4	200	18,6	13-4	6,0
90	8,4	5-14	2,7	210	19,5	14-0	6,4
100	9,3	6-9	3,0	220	20,4	14-12	6,7
110	10,2	7-5	3,3	230	21,4	15-7	7,0
120	11,1	7-15	3,6	240	22,3	16-0	7,3
130	12,1	8-9	3,9	250	23,2	16-12	7,6
140	13,0	9-4	4,2	260	24,2	17-13	7,9

Table 5

The required minimum room area

Mc(□lb□oz)		Amin/TAmin(ft ²)	Mc(□lb□oz)		Amin/TAmin(ft ²)
lb	oz		lb	oz	
4	6	66.1	11	0	165.3
4	13	72.7	11	7	171.9
5	4	79.3	11	14	178.5
5	11	86.0	12	5	185.1
6	2	92.6	12	12	191.7
6	9	99.2	13	3	198.4
7	0	105.8	13	10	205.0
7	7	112.4	14	1	211.6
7	15	119.0	14	8	218.2
8	6	125.6	14	15	224.8
8	13	132.2	15	6	231.4
9	4	138.8	15	14	238.0
9	11	145.5	16	5	244.6
10	2	152.1	16	12	251.2
10	9	158.7	17	3	257.9

Table 6

The minimum circulation airflow

Mc(□lb□oz)		Qmin(CFM)	Mc(□lb□oz)		Qmin(CFM)
lb	oz		lb	oz	
4	6	119	11	0	298
4	13	131	11	7	310
5	4	143	11	14	322
5	11	155	12	5	334
6	2	167	12	12	346
6	9	179	13	3	358
7	0	191	13	10	370
7	7	203	14	1	382
7	15	215	14	8	394
8	6	227	14	15	406
8	13	239	15	6	418
9	4	251	15	14	430
9	11	263	16	5	442
10	2	275	16	12	454
10	9	287	17	3	466

Table 7

If the altitude of installation is higher than 2000 ft, the required minimum room area follow as Table8.

Charge lb	Altitude(m)							
	201-400	401-600	601-800	801-1000	1001-1200	1201-1400	1401-1600	above 1600
	Minimum Conditioned Space(m ²)							
2	2.8	2.8	2.8	2.9	3.0	3.1	3.1	3.2
3	4.2	4.2	4.3	4.4	4.5	4.6	4.7	4.8
4	5.6	5.6	5.7	5.9	6.0	6.1	6.2	6.4
5	7.0	7.0	7.1	7.3	7.5	7.7	7.8	8.0
6	8.4	8.4	8.5	8.8	8.9	9.2	9.4	9.6
7	9.8	9.8	9.9	10.2	10.4	10.7	10.9	11.2
8	11.1	11.1	11.4	11.7	11.9	12.3	12.5	12.8
9	12.5	12.5	12.8	13.2	13.4	13.8	14.0	14.4
10	13.9	13.9	14.2	14.6	14.9	15.3	15.6	16.0
11	15.3	15.3	15.6	16.1	16.4	16.9	17.2	17.6
12	16.7	16.7	17.1	17.6	17.9	18.4	18.7	19.2
13	18.1	18.1	18.5	19.0	19.4	19.9	20.3	20.8
14	19.5	19.5	19.9	20.5	20.9	21.5	21.8	22.4
15	20.9	20.9	21.3	21.9	22.4	23.0	23.4	24.0
16	22.3	22.3	22.7	23.4	23.8	24.5	25.0	25.6
17	23.7	23.7	24.2	24.9	25.3	26.1	26.5	27.2
18	25.1	25.1	25.6	26.3	26.8	27.6	28.1	28.8
19	26.5	26.5	27.0	27.8	28.3	29.1	29.6	30.4
20	27.9	27.9	28.4	29.3	29.8	30.6	31.2	32.0

Table 8

CAUTION

The allowable maximum refrigerant charge of the Table5 or the required minimum room area of the Table6 is available only if the following conditions are met:
 Minimum velocity of 3.28 ft/s, which is calculated as the indoor unit airflow divided by the nominal face area of the outlet. The grill area shall not be deducted.
 Minimum airflow rate must meet the corresponding values in Table 7, which is related to the actual refrigerant charge of the system (Mc).
 R454B refrigerant leakage sensor is configured.

NOTE

The maximum refrigerant limit described above applies to unventilated areas. If adding additional measures, such as areas with mechanical ventilation or natural ventilation, the maximum refrigerant charge can be increased or the minimum room area can be reduced.
 The R454B refrigerant leakage sensor is configured for the indoor unit and meets the incorporated circulation airflow requirements.
 The maximum refrigerant charge or minimum room area can be determined according to Table5 or Table 6.

CAUTION

If the actual room area, air outlet height, and refrigerant charge amount are not reflected in the above table, more severe cases need to be considered according to the data in the Table 4, 5, 6, 7.

4.0 ELECTRICAL WIRING

Field wiring must comply with the National Electric Code and any applicable local ordinance.

WARNING

Disconnect all power to unit before installing or servicing. More than one disconnect switch may be required to de-energize the equipment. Hazardous voltage can cause severe personal injury or death.

4.1 POWER WIRING

It is important that proper electrical power is available for connection to the unit model being installed. See the unit nameplate, wiring diagram and electrical data in the installation instructions.

- If required, install a branch circuit disconnect of adequate size, located within sight of, and readily accessible to the unit.
- **IMPORTANT:** After the Electric Heater is installed, units may be equipped with one, two, or three 30/60 amp. circuit breakers. These breaker(s) protect the internal wiring in the event of a short circuit and serve as a disconnect. Circuit breakers installed within the unit do not provide over-current protection of the supply wiring and therefore may be sized larger than the branch circuit protection.
- Supply circuit power wiring must be 75°C minimum copper conductors only. See Electrical Data In this section for ampacity, wire size and circuit protector requirement. Supply circuit protective devices may be either fuses or "HACR" type circuit breakers.
- Power wiring may be connected to either the right, left side or top. concentric knockouts are provided for connection of power wiring to unit.

4.2 CONTROL WIRING

IMPORTANT: Class 2 low voltage control wiring should not be run in conduit with main power wiring and must be separated from power wiring, unless class 1 wire of proper voltage rating is used.

- Low voltage control wiring should be 18 Awg. color-coded. For lengths longer than 100 ft., 16 Awg. wire should be used.
- See wiring diagrams attached to indoor and outdoor sections to be connected.
- Make sure, after installation, separation of control wiring and power wiring has been maintained.

4.3 GROUNDING

WARNING

The unit must be permanently grounded. Failure to do so can result in electrical shock causing personal injury or death.

- Grounding may be accomplished by grounding metal conduit when installed in accordance with electrical codes to the unit cabinet.
- Grounding may also be accomplished by attaching ground wire(s) to ground lug(s) provided in the unit wiring compartment.
- Ground lug(s) are located close to wire entrance on left side of unit (up-flow). Lug(s) may be moved to marked locations near wire entrance on right side of unit (upflow). If alternate location is more convenient.
- Use of multiple supply circuits require grounding of each circuit to lug(s) provided in unit.

4.4 ELECTRICAL DATA

MODEL	VOLTAGE	HERTZS	HP	RPM	SPEEDS	CIRCUIT AMPS.	MAXIMUM CIRCUIT PROTECTOR
18K	208/230	60	1/4	710	3	1.2	3(A)
24K	208/230	60	2/7	770	3	1.4	3(A)
30K	208/230	60	1/2	1050	5	3.2	6(A)
36K	208/230	60	1/2	1050	5	3.2	6(A)
42K	208/230	60	3/4	1050	5	5.5	10(A)
48K	208/230	60	3/4	1050	5	5.5	10(A)
60K	208/230	60	3/4	1050	5	5.5	10(A)

4.5 MCA/MOP data of electric heat kit

Heater Kit Model	Air Handler Model	Electric Heater (kW)	MCA (Min. Circuit Ampacity)		MOP (Max. Fuse or Breaker (HACR) Ampacity)		Fan Speed (AC/HP)				
			208V	230V	208V	230V	1 (Low)	2	3 (Medium)	4	5 (High)
AP-HR50-01	18K	5	22.8	24.9	25	25		/		/	
AP-HR75-01		7.5	34.8	37.9	35	40		/		/	
AP-HR50-01	24K	5	22.8	24.9	25	25		/		/	
AP-HR75-01		7.5	34.8	37.9	35	40		/		/	
AP-HR100-01		10	45.4	49.8	50	50		/		/	
AP-HR50-01	30K	5	22.8	24.9	25	25					
AP-HR75-01		7.5	34.8	37.9	35	40					
AP-HR100-01		10	45.4	49.8	50	50					
AP-HR50-01	36K	5	22.8	24.9	25	25					
AP-HR75-01		7.5	34.8	37.9	35	40					
AP-HR100-01		10	45.4	49.8	50	50					
AP-HR150-01		15	34.8/34.8	37.9/37.9	35/35	40/40	x				
AP-HR50-01	42K	5	22.8	24.9	25	25	x				
AP-HR75-01		7.5	34.8	37.9	35	40	x				
AP-HR100-01		10	45.4	49.8	50	50	x				
AP-HR150-01		15	34.8/34.8	37.9/37.9	35/35	40/40	x				
AP-HR200-01		20	45.4/45.4	49.8/49.8	50/50	50/50	x				
AP-HR50-01	48K	5	22.8	24.9	25	25	x				
AP-HR75-01		7.5	34.8	37.9	35	40	x				
AP-HR100-01		10	45.4	49.8	50	50	x				
AP-HR150-01		15	34.8/34.8	37.9/37.9	35/35	40/40	x				
AP-HR200-01		20	45.4/45.4	49.8/49.8	50/50	50/50	x				
AP-HR50-01	60K	5	22.8	24.9	25	25	x	x	x		
AP-HR75-01		7.5	34.8	37.9	35	40	x	x	x		
AP-HR100-01		10	45.4	49.8	50	50	x	x	x		
AP-HR150-01		15	34.8/34.8	37.9/37.9	35/35	40/40	x	x	x		
AP-HR200-01		20	45.4/45.4	49.8/49.8	50/50	50/50	x	x	x		

NOTE:

Heat kit suitable for AHU 4-way position installation.

Ampacities for MCA and Fuse/breaker including the blower motor.

Heat pump systems require a specified airflow. Each ton of cooling requires between 350 and 450 cubic feet of air per minute (CFM), or 400 CFM nominally.

Electrical Heater Kits		
Model	Description	Ref. Air Handler Use
AP-HR50-01	5kW heater kit, double pole circuit breaker	18/24/30/36/42/48/60
AP-HR75-01	7.5kW heater kit, double pole circuit breaker	18/24/30/36/42/48/60
AP-HR100-01	10kW heater kit, double pole circuit breaker	24/30/36/42/48/60
AP-HR150-01	15kW heater kit, double pole circuit breaker	36/42/48/60
AP-HR200-01	20kW heater kit, double pole circuit breaker	42/48/60

5.0 Airflow performance

Airflow performance data is based on cooling performance with a coil and no filter in place. Select performance table for appropriate unit size.

External static applied to unit allows operation within the minimum and maximum limits shown in table below for both cooling and electric heat operation.

Model	Blower Speeds	External Static Pressure (in.w.c .)								
		0	0.1	0.2	0.3	0.4	0.5	0.6	0.7	0.8
18K	L	887	838	772	683	618	550	507	/	/
	M-Factory Default	1086	1041	993	932	823	749	673	587	529
	H	1134	1090	1039	982	869	784	704	614	528
24K	L-Factory Default	1127	1082	1028	973	856	761	679	574	526
	M	1193	1144	1092	1031	897	803	717	622	531
	H	1292	1240	1185	1120	1037	885	787	693	553
30K	2	1131	1074	1012	950	893	836	779	727	679
	3-Factory Default	1245	1197	1145	1093	1045	983	917	865	817
	4	1359	1316	1270	1226	1183	1131	1074	1007	945
	5	1449	1411	1368	1325	1287	1245	1197	1126	1059
36K	2	1131	1074	1012	950	893	836	779	727	679
	3	1245	1197	1145	1093	1045	983	917	865	817
	4-Factory Default	1359	1316	1270	1226	1183	1131	1074	1007	945
	5	1449	1411	1368	1325	1287	1245	1197	1126	1059
42K	2	1298	1257	1216	1162	1107	1011	961	918	873
	3-Factory Default	1451	1414	1379	1344	1301	1254	1217	1085	1005
	4	1588	1550	1512	1476	1440	1402	1368	1202	1035
	5	1730	1695	1660	1611	1562	1484	1410	1224	1037
48K	2	1404	1360	1316	1267	1219	1170	1136	1051	964
	3	1585	1544	1503	1467	1431	1388	1344	1288	1231
	4-Factory Default	1730	1689	1655	1621	1587	1549	1514	1457	1416
	5	1887	1852	1815	1780	1745	1707	1681	1599	1517
60K	2	1404	1360	1316	1267	1219	1170	1136	1051	964
	3	1585	1544	1503	1467	1431	1388	1344	1288	1231
	4-Factory Default	1730	1689	1655	1621	1587	1549	1514	1457	1416
	5	1887	1852	1815	1780	1745	1707	1681	1599	1517

Note:

1. The advanced airflow must be used as the rated airflow for the full-load operation of the machine.
2. The rated airflow of a system without an electric heater kit requires 300 to 450 cubic feet of air per minute (CFM).
3. The rated airflow of a system with an electric heater kit requires 350 to 450 cubic feet of air per minute(CFM).
4. The air distribution system has the greatest influence on air flow. Therefore, the contractor should only use the procedures recognized by the industry.
- 5 The design and construction of air duct should be done carefully. Poor design or process will lead to a significant decline in system performance.
6. The air supply duct should be set along the periphery of the air-conditioned space with appropriate size. Improper location of insufficient airflow may lead to insufficient ventilation or noise in the pipeline system.
7. The installer should balance the air distribution system to ensure that all rooms in the room have proper quiet airflow. The speedometer or airflow hood can be used to balance and verify the branch pipe and system airflow (CFM).

Important:

1. When model 36 used with electrical heater kit model HR150-01, you need to ensure that the air volume is not less than 1100 CFM.
2. When model 42 used with electrical heater kit model HR150-01 and HR200-01, you need to ensure that the air volume is not less than 1280 CFM.
3. When model 48 used with electrical heater kit model HR150-01 and HR200-01, you need to ensure that the air volume is not less than 1415 CFM.

6.0 REFRIGERANT CONNECTIONS

Keep the coil connections sealed until refrigerant connections are made. See the Installation Instructions for the outdoor unit for details on line sizing, tubing installation, and charging information. Coil is shipped with "No charge". Evacuate the system before charging with refrigerant. Install refrigerant tubing so that it does not block service access to the front of the unit. Nitrogen should flow through the refrigerant lines while brazing. Use a brazing shield to protect the cabinet's paint and a wet rag to protect the rubber grommet from being damaged by torch flames. After the refrigerant connections are made, seal the gap around the connections with pressure sensitive gasket.

6.1 CONDENSATE DRAIN TUBING

Consult local codes for specific requirements.

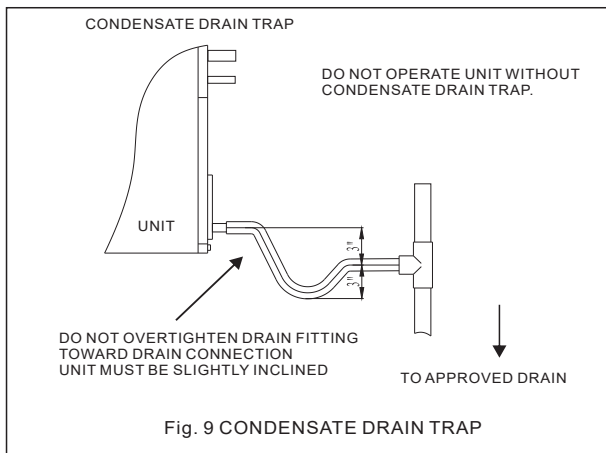

IMPORTANT:

- When making drain fitting connections to the drain pan, use a thin layer of Teflon paste, silicone or Teflon tape and install, hand tighten.
 - When making drain fitting connections to drain pan, do not over tighten. Over tightening fittings can split pipe connections on the drain pan.
- Install drain lines so they do not block service access to front of the unit. Minimum clearance of 24 inches is required for filter, coil or blower removal and service access.
 - Make sure unit is level or pitched slightly toward primary drain connection so that water will drain completely from the pan. (See Fig. 9)
 - Do not reduce drain line size less than connection size provided on condensate drain pan.
 - All drain lines must be pitched downward away from the unit a minimum of 1/8" per foot of line to ensure proper drainage.
 - Do not connect condensate drain line to a closed or open sewer pipe. Run condensate to an open drain or run line to a safe outdoor area.
 - The drain line should be insulated where necessary to prevent sweating and damage due to condensate forming on the outside surface of the line.

- Make provisions for disconnecting and cleaning of the primary drain line should it become necessary. Install a 3 inch trap in the primary drain line as close to the unit as possible. Make sure that the top of the trap is below connection to the drain pan to allow complete drainage of pan (See Fig. 9).
- Auxiliary drain line should be run to a place where it will be noticeable if it becomes operational. Homeowner should be warned that a problem exists if water should begin running from the auxiliary drain line.
- Plug the unused drain connection with the plugs provided in the parts bag, using a thin layer of teflon paste, silicone or teflon tape to form a water tight seal.
- Test condensate drain pan and drain line after installation is complete. Pour water into drain pan, enough to fill drain trap and line. Check to make sure drain pan is draining completely, no leaks are found in drain line fittings, and water is draining from the termination of the primary drain line.

7.0 AIR FILTER (not factory-installed)

- External filter or other means of filtration is required. Units should be sized for a maximum of 300 feet/min. air velocity or what is recommended for the type filter installed. Filter application and placement are critical to airflow, which may affect the heating and cooling system performance. Reduced airflow can shorten the life of the system's major components, such as motor, limits, elements, heat relays, evaporator coil or compressor. Consequently, we recommend that the return air duct system have only one filter location. For systems with a return air filter grill or multiple filter grills, can have a filter installed at each of the return air openings. If adding high efficiency filters or electronic air filtration systems, it is very important that the air flow is not reduced. If air flow is reduced the overall performance and efficiency of the unit will be reduced. It is strongly recommended that a professional installation technician is contacted to ensure installation of these such filtration systems are installed correctly.
- IMPORTANT: DO NOT DOUBLE FILTER THE RETURN AIR DUCT SYSTEM. DO NOT FILTER THE SUPPLY AIR DUCT SYSTEM. THIS WILL CHANGE THE PERFORMANCE OF THE UNIT AND REDUCE AIRFLOW .**

WARNING

Do not operate the system without filters. A portion of the dust entrained in the air may temporarily lodge in the duct runs and at the supply registers. Any circulated dust particles could be heated and charred by contact with the air handler elements. This residue could soil ceilings, walls, drapes, carpets and other articles in the house. Soot damage may occur with filters in place, when certain types of candles, oil lamps or standing pilots are burned.

8.0 FILTER INSTALLATION DIMENSIONS

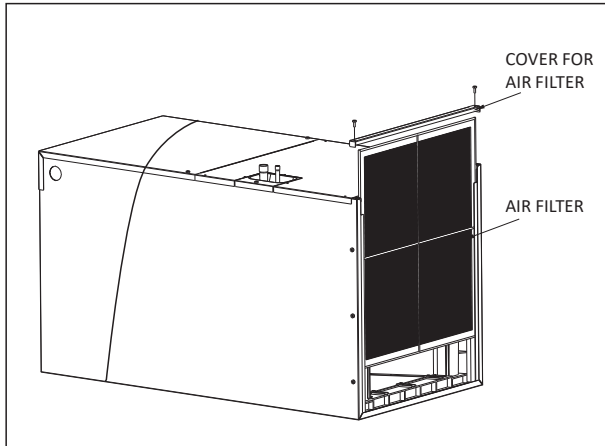

Fig. 10 EXTERNAL FILTER BASE

DIMENSIONAL DATA

MODEL	FILTER SIZE IN[mm]
18/24/30/36/42	18.1×21.4[460×544]
48/60	20.5×23.8[521×605]

NOTE: The thickness of the filter should be within 1" [25mm].

AIR FILTER REMOVAL

1. Tear down the two bolts signed A and B, take down the cover for air filter, see in Figure 4.
2. Hold the edge of the air filter and extract out .
3. Clean the air filter (Vacuum cleaner or pure water may be used to clean the air filter. If the dust accumulation is too heavy, use soft brush and mild detergent to clean it and dry out in cool place) .

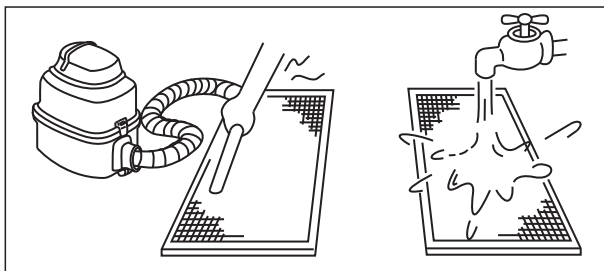

9.0 WIRING DIAGRAM

1. To avoid the electrical shock, please connect the air conditioner with the ground lug. The main power plug in the air conditioner has been joined with the ground wiring, please don't change it freely.
2. The power socket is used as the air conditioner specially.
3. Don't pull the power wiring hard.
4. When connecting the air conditioner with the ground, observe the local codes.
5. If necessary, use the power fuse or the circuit, breaker or the corresponding scale ampere.

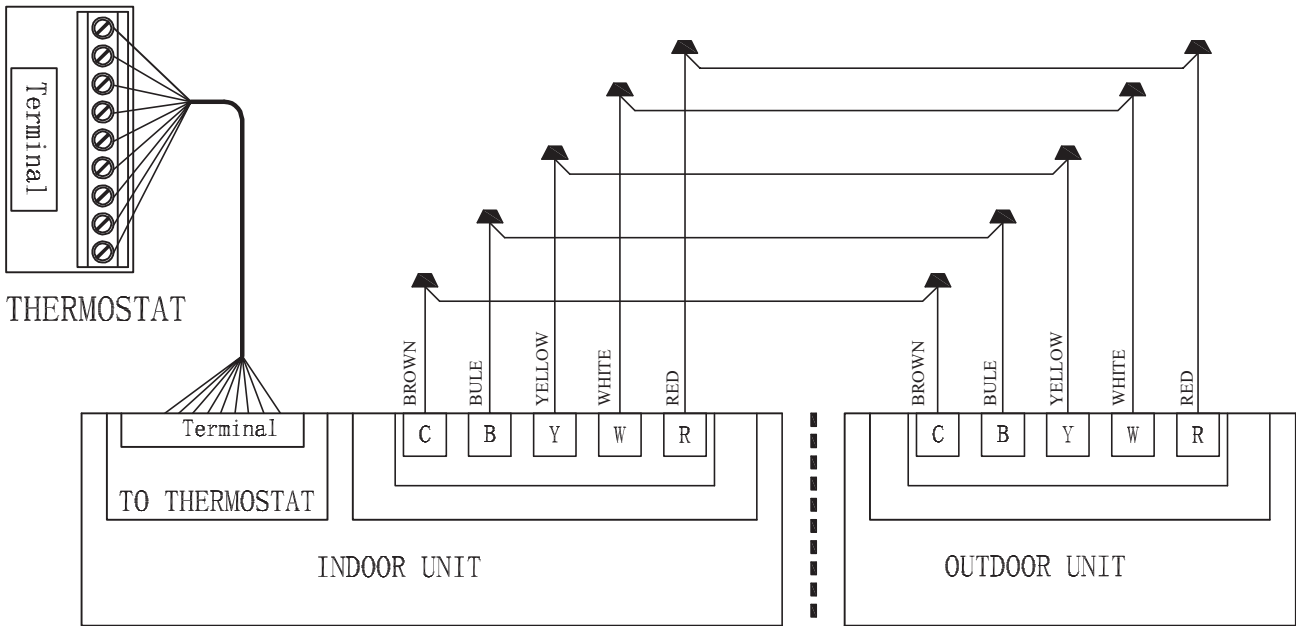

Wiring connection for H/P Systems

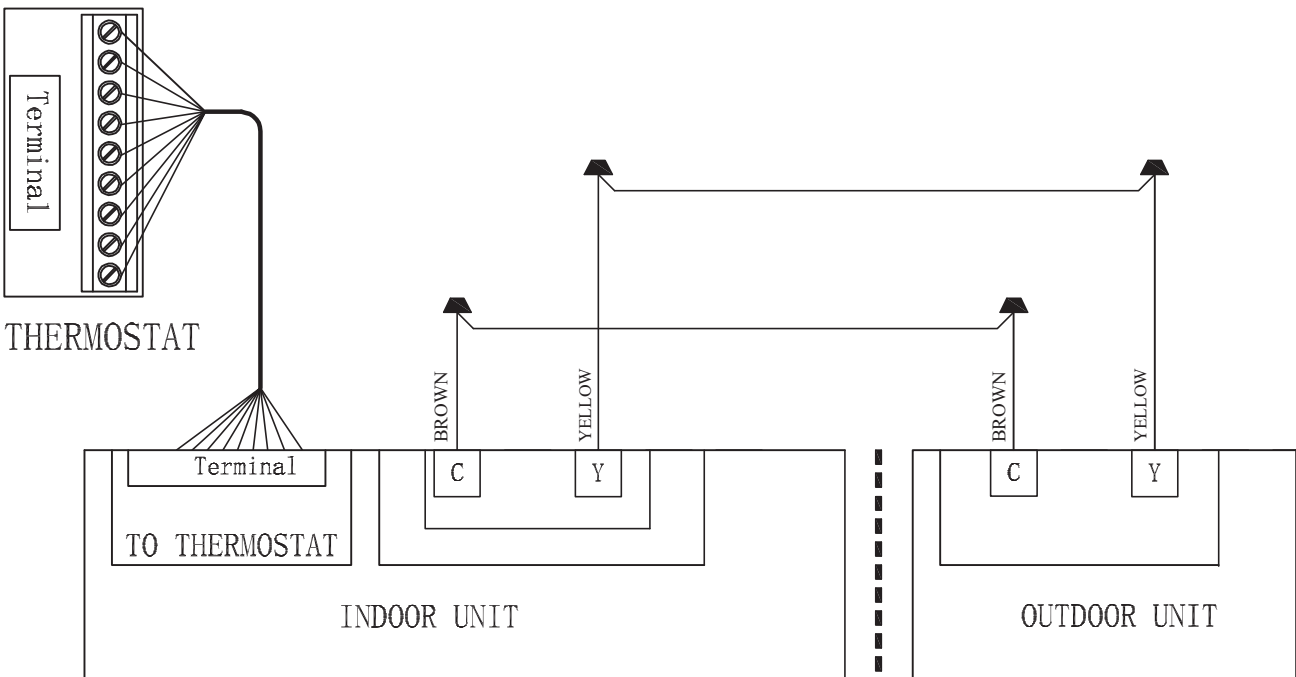

Wiring connection for A/C Systems

Applicable to 18K

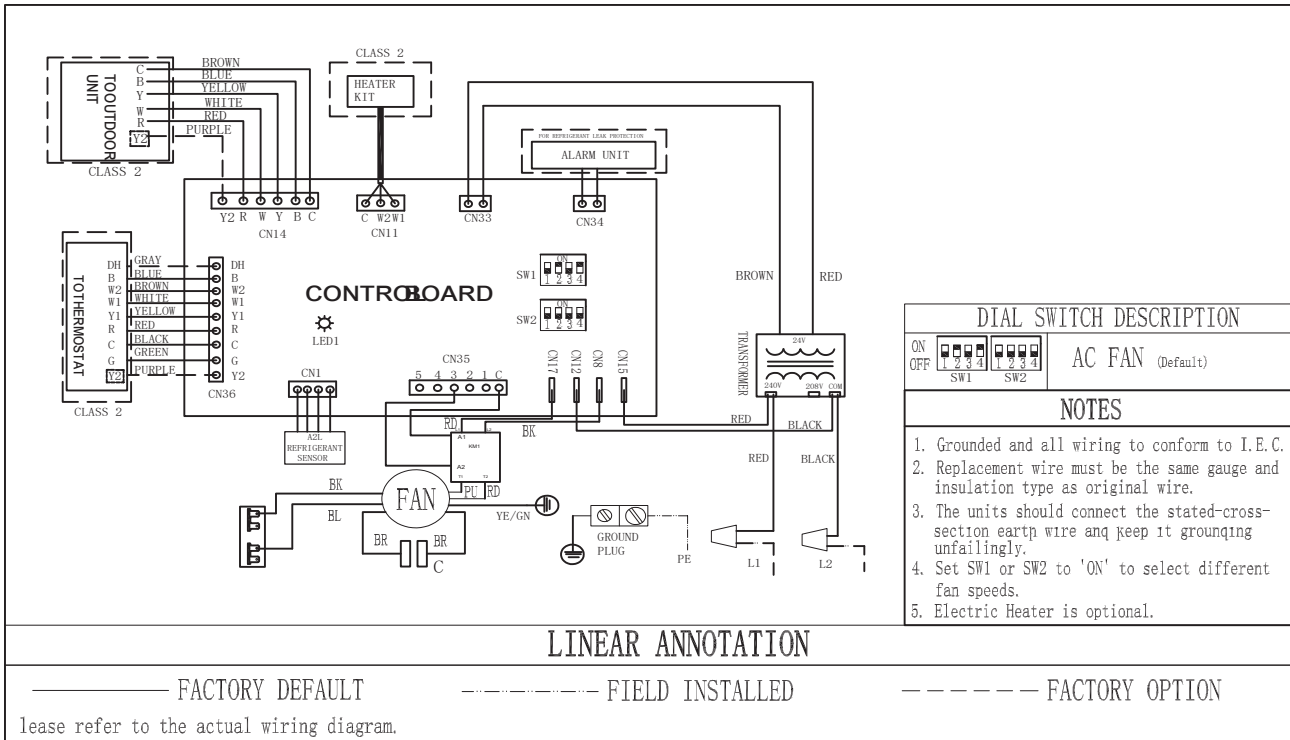

Applicable to 24K

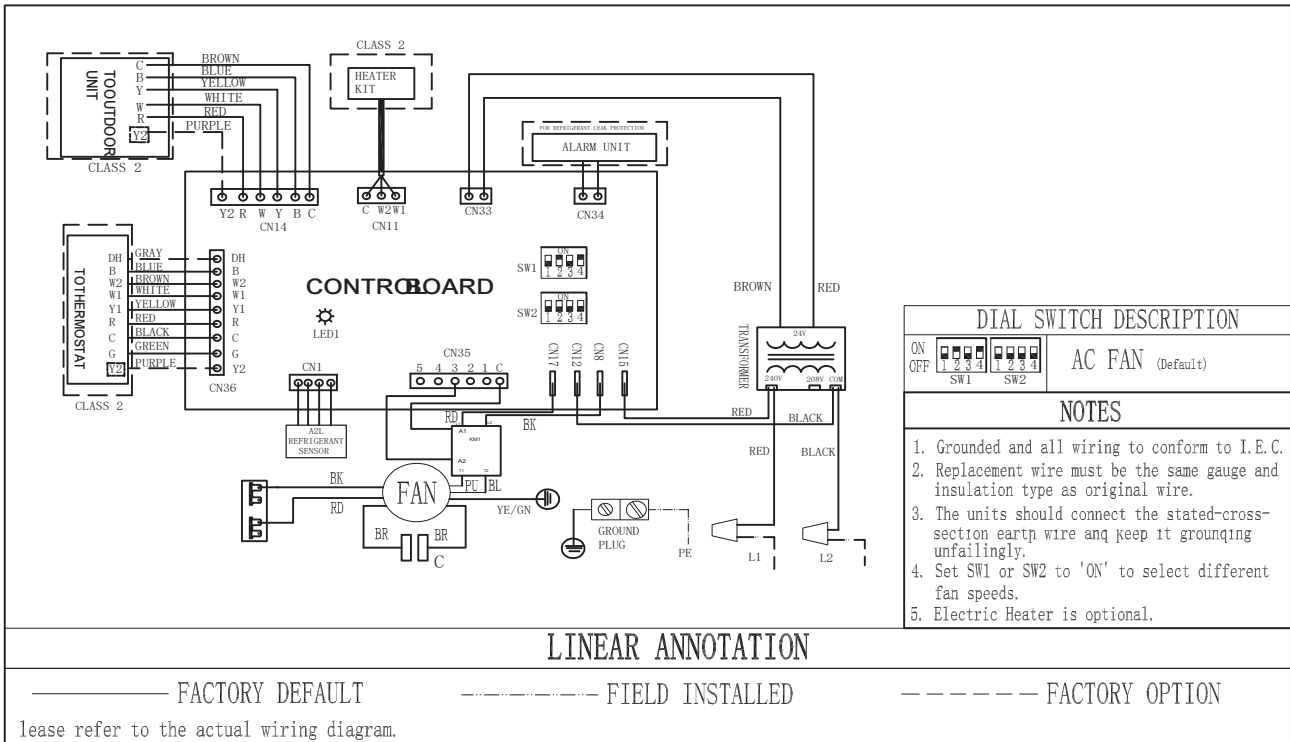

Note: Explanation of Fan Speed Switch

- 1.Low windshield: The red wire of the motor is connected to the terminal block, and the blue wire is connected to the relay (swap plug positions).
- 2.Medium speed wiring: The blue wire of the motor is connected to the terminal block, and the red wire is connected to the relay (swap plug positions).

Applicable to 30K/36K/42K/48K/60K

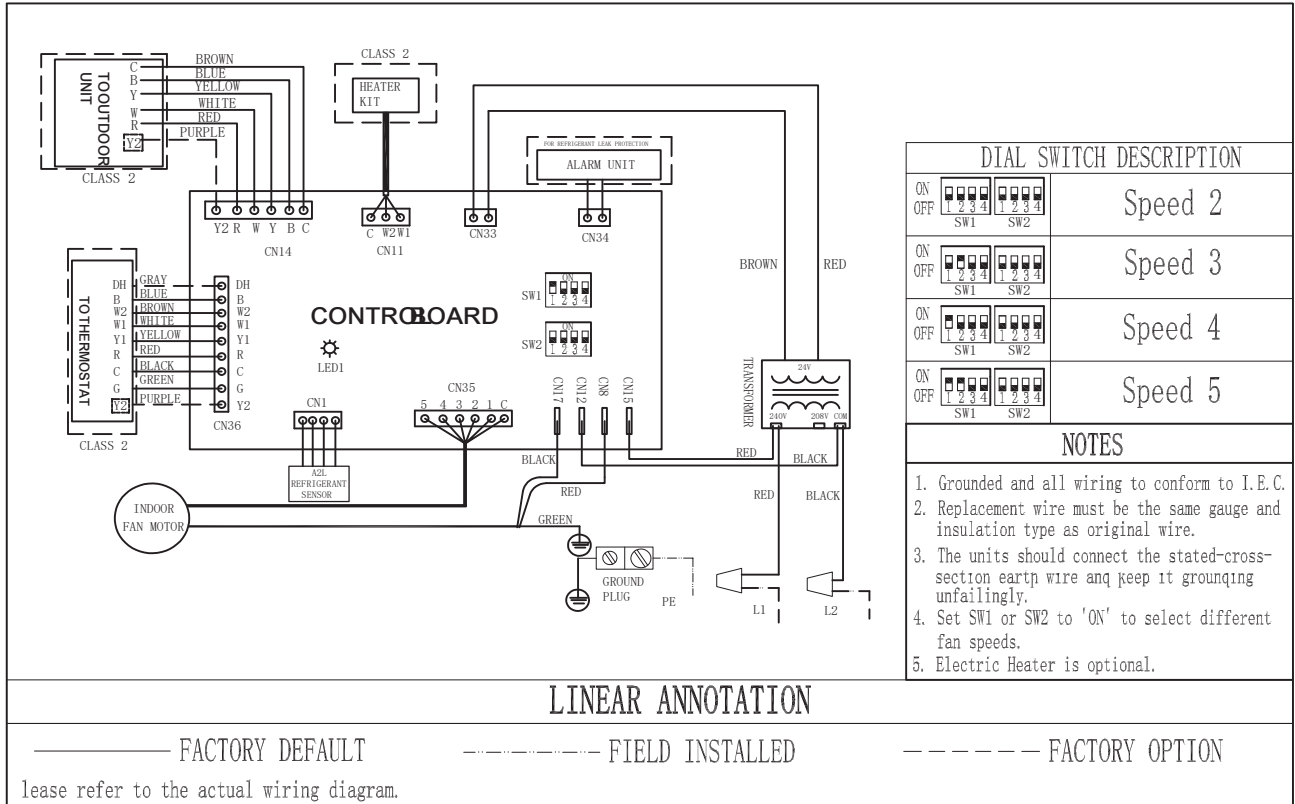

DIAL SWITCH DESCRIPTION		
ON	<input type="checkbox"/> <input type="checkbox"/> <input type="checkbox"/> <input type="checkbox"/>	Speed 2
OFF	<input type="checkbox"/> <input type="checkbox"/> <input type="checkbox"/> <input type="checkbox"/>	
ON	<input type="checkbox"/> <input type="checkbox"/> <input type="checkbox"/> <input type="checkbox"/>	Speed 3
OFF	<input type="checkbox"/> <input type="checkbox"/> <input type="checkbox"/> <input type="checkbox"/>	
ON	<input type="checkbox"/> <input type="checkbox"/> <input type="checkbox"/> <input type="checkbox"/>	Speed 4
OFF	<input type="checkbox"/> <input type="checkbox"/> <input type="checkbox"/> <input type="checkbox"/>	
ON	<input type="checkbox"/> <input type="checkbox"/> <input type="checkbox"/> <input type="checkbox"/>	Speed 5
OFF	<input type="checkbox"/> <input type="checkbox"/> <input type="checkbox"/> <input type="checkbox"/>	
NOTES		
1. Grounded and all wiring to conform to I.E.C. 2. Replacement wire must be the same gauge and insulation type as original wire. 3. The units should connect the stated-cross-section earth wire and keep it grounding unfaithfully. 4. Set SW1 or SW2 to 'ON' to select different fan speeds. 5. Electric Heater is optional.		

DIP Switch	Fan Speed	Model	DIP Switch	Fan Speed	Model
ON <input type="checkbox"/> <input type="checkbox"/> <input type="checkbox"/> <input type="checkbox"/> <input type="checkbox"/> <input type="checkbox"/> <input type="checkbox"/> <input type="checkbox"/> OFF <input type="checkbox"/> <input type="checkbox"/> <input type="checkbox"/> <input type="checkbox"/> <input type="checkbox"/> <input type="checkbox"/> <input type="checkbox"/> <input type="checkbox"/> SW1 SW2	Speed 2	18K、24K	ON <input type="checkbox"/> <input type="checkbox"/> <input type="checkbox"/> <input type="checkbox"/> <input type="checkbox"/> <input type="checkbox"/> <input type="checkbox"/> <input type="checkbox"/> OFF <input type="checkbox"/> <input type="checkbox"/> <input type="checkbox"/> <input type="checkbox"/> <input type="checkbox"/> <input type="checkbox"/> <input type="checkbox"/> <input type="checkbox"/> SW1 SW2	Speed 4	36K、60K
ON <input type="checkbox"/> <input type="checkbox"/> <input type="checkbox"/> <input type="checkbox"/> <input type="checkbox"/> <input type="checkbox"/> <input type="checkbox"/> <input type="checkbox"/> OFF <input type="checkbox"/> <input type="checkbox"/> <input type="checkbox"/> <input type="checkbox"/> <input type="checkbox"/> <input type="checkbox"/> <input type="checkbox"/> <input type="checkbox"/> SW1 SW2	Speed 3	30K	ON <input type="checkbox"/> <input type="checkbox"/> <input type="checkbox"/> <input type="checkbox"/> <input type="checkbox"/> <input type="checkbox"/> <input type="checkbox"/> <input type="checkbox"/> OFF <input type="checkbox"/> <input type="checkbox"/> <input type="checkbox"/> <input type="checkbox"/> <input type="checkbox"/> <input type="checkbox"/> <input type="checkbox"/> <input type="checkbox"/> SW1 SW2	Speed 5	48K

10.0 Low voltage wires connections with thermostat .

10.1 Connect the Control communication cables by wire nut.

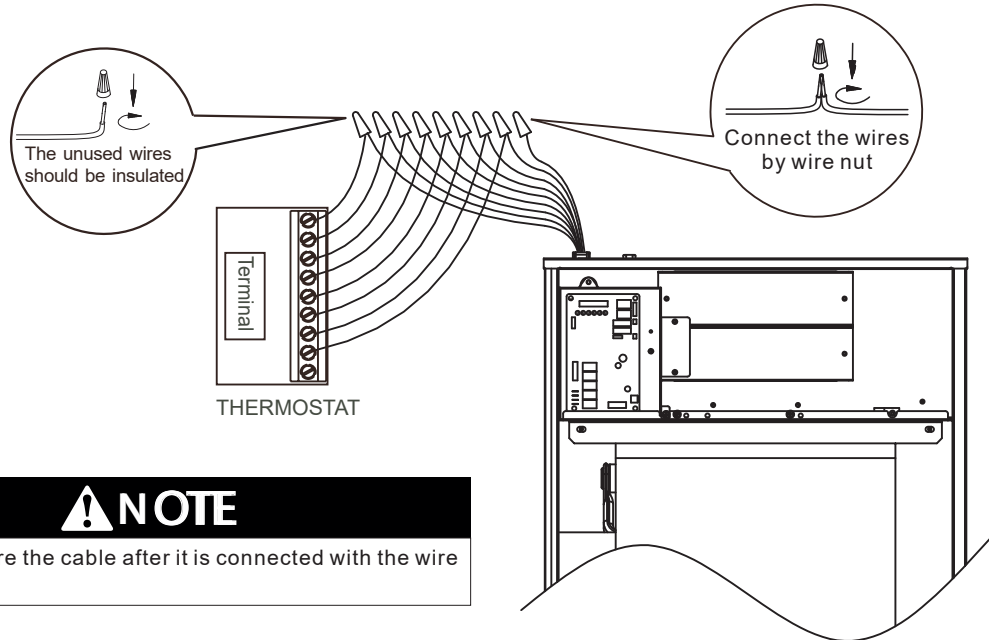

10.2 Wiring diagram of the thermostat.

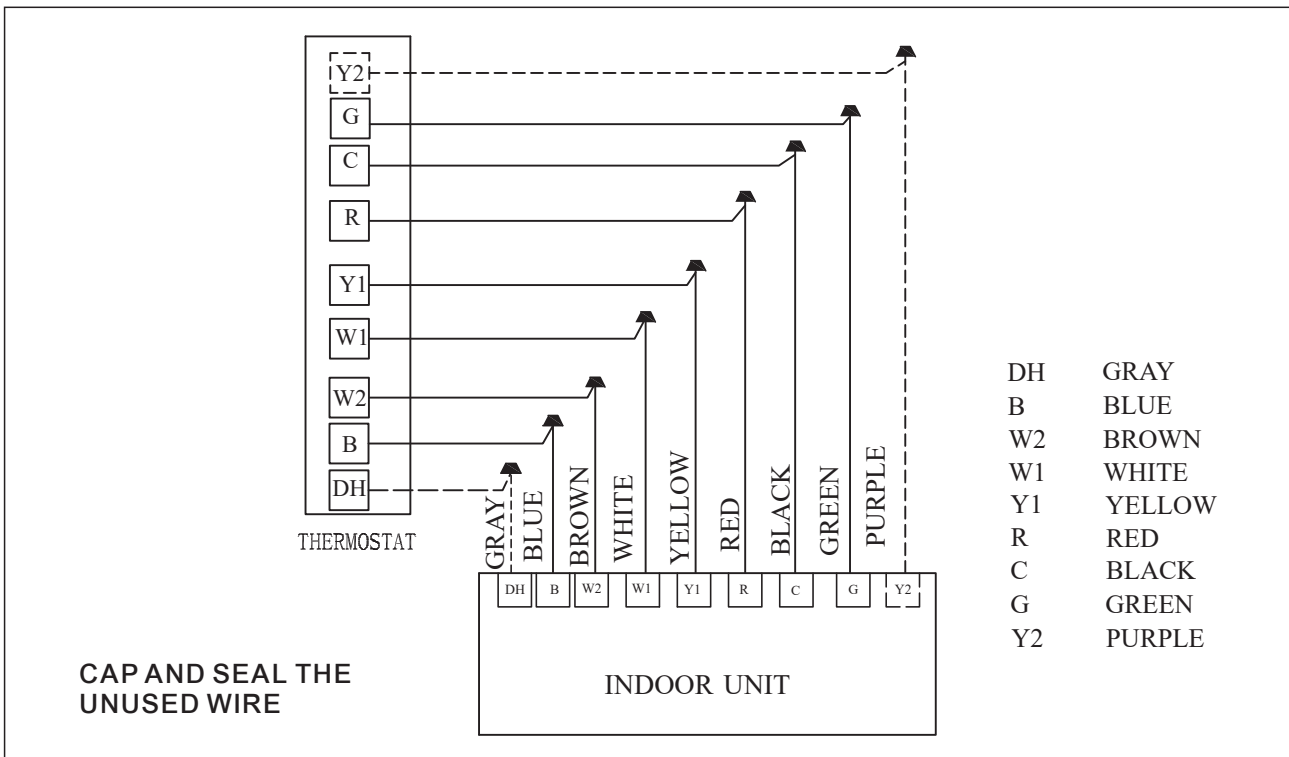

10.3 Power Wiring

In the U.S.A., wiring must conform with current local codes and the current National Electric Code (NEC). In Canada, wiring must conform with current local codes and the current Canadian Electrical Code (CEC).

WARNING

Installation and servicing of air conditioning equipment can be hazardous due to internal refrigerant pressure and live electrical components. Only trained and qualified service personnel should install or service this equipment. Installation and service performed by unqualified persons can result in property damage, personal injury, or death.

Risk of electrical shock. Disconnect all remote power supplies before installing or servicing any portion of the system. Failure to disconnect power supplies can result in property damage, personal injury, or death.

Fire Hazard. Use of aluminum wire with this product may result in a fire, causing property damage, severe injury or death. Use copper wire only with this product.

Can cause injury or death. Unit must be properly grounded in accordance with national and local codes.

Natural grounding poles embedded in the ground can be used, but do not connect the ground wire to the following locations:

- (a) Pipes of flammable or explosive gases, which may otherwise lead to an explosion or fire.
- (b) Insulated plastic pipes, otherwise there is no grounding effect.
- (c) Telephone line or lightning rod, otherwise it will be dangerous for increasing the ground potential during lightning strikes.

CAUTION

Sharp metal edges can cause injury. When installing the unit, use care to avoid sharp edges.

Avoid sharp metal edges for wires to prevent wear, or it may lead to short circuit or electric leakage and cause danger.

Wires should be fixed well. Otherwise, the connectors may be loose or the terminal may be damaged when they are pulled.

WARNING

The unit must be permanently grounded. Failure to do so can result in electrical shock causing personal injury or death.

NOTE

Electrostatic discharge can affect electronic components. Take care during unit installation and service to protect the unit's electronic controls. Precautions will help to avoid control exposure to electrostatic discharge by putting the unit, the control and the technician at the same electrostatic potential. It is strongly recommended to contact a professional installation technician to ensure the correct installation of such filtration systems.

Do not add phase junction capacitors, otherwise it may cause serious damage to the product.

Do not start the unit before installing pipes. Otherwise, the compressor will be damaged.

11.0 ELECTRIC WIRING GAUGE

Note:

The cross-section areas of wires or lines should not be less than the corresponding ones listed in the table below; Besides, if the power wires is quite long from the unit, please choose the windings with larger cross-section area to guarantee the normal power supply.

Model (cooling only type)			18K	24K	30K	36K	42K	48K	60K
Line Gauge	Indoor Unit Power Line	Line Quantity	3	3	3	3	3	3	3
		Line Diameter(AWG)	16	16	16	16	16	16	16
	Outdoor Unit Power Line	Line Quantity	3	3	3	3	3	3	3
		Line Diameter(AWG)	14	14	12	12	10	10	8
	Indoor-Thermostat Singal Line	Line Quantity	5	5	5	5	5	5	5
		Line Diameter(AWG)	18	18	18	18	18	18	18
	Outdoor-Thermostat Singal Line	Line Quantity	2	2	2	2	2	2	2
		Line Diameter(AWG)	18	18	18	18	18	18	18

Model (cooling & heating type)			18K	24K	30K	36K	42K	48K	60K
Line Gauge	Indoor Unit Power Line	Line Quantity	3	3	3	3	3	3	3
		Line Diameter(AWG)	16	16	16	16	16	16	16
	Outdoor Unit Power Line	Line Quantity	3	3	3	3	3	3	3
		Line Diameter(AWG)	14	14	12	12	10	10	8
	Indoor-Thermostat Singal Line	Line Quantity	5	5	5	5	5	5	5
		Line Diameter(AWG)	18	18	18	18	18	18	18
	Outdoor-Thermostat Singal Line	Line Quantity	5	5	5	5	5	5	5
		Line Diameter(AWG)	18	18	18	18	18	18	18